

Motor Reversing Module

Specification

Description

The forward and reverse module automatically reverses the direction of the motor when the appropriate control circuit is energized with a pulse from a control switch. Dynamic breaking stops the motor when the switch returns to Off. Ideal for tarp or lift applications as well as for use on hoists, hatches, winches, snowplows, intake/exhaust fans, vehicle outriggers and other reversing applications.

Low-profile module saves space. Studs are securely anchored in epoxy. Tin-plated brass studs and hardware for corrosion resistance



Technical Parameters

Part number : 2300-1001 -A no hardware
2300-1001-B with hardware

Contact Forms	1A ~ 1C
Contact Material	Silver alloy
Intermittent Load	50Amp at 12 VDC
Continuous Load	30Amp at 12 VDC
Contact Resistance	50mΩ
Coil Voltage	12V ~ 24V
Coil Power	1.8W
Dielectric Strength Contacts Between	550VAC
Dielectric Strength Between Cold & Contacts	750VAC
Insulation Resistance	100MΩ
Electrical Life	1x100,000
Mechanical Life	1x10,000,000
Ambient Temperature	(-40 ~ ±85°C)
Pull-in Time / Voltage	10ms/≥70%
Release Time / Voltage	5ms/≥10%
Dimensions	4.88" x 2.20" x 1.37"
IP Rating	IP67
Ignition Protection	ISO 8846 and SAE J1171
Tin-Plated Brass Studs	10-32 x 4pcs , 8-32 x 2pcs

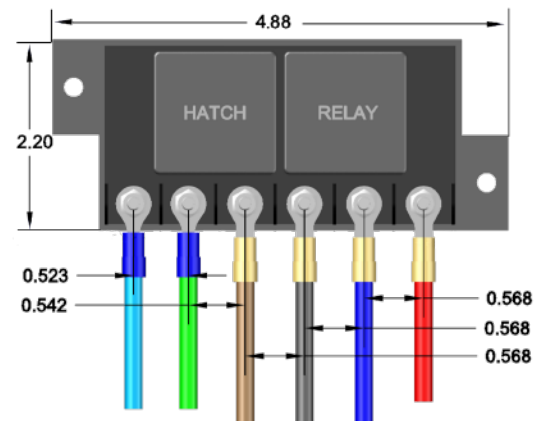
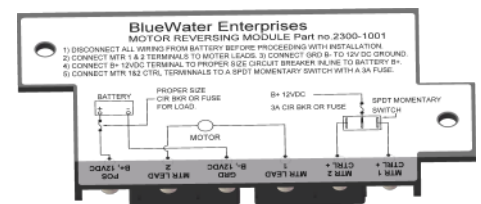

Wiring & Installation

