

HARDIN MARINE 11 Industry Dr. Palm Coast, FL 32137
 386-445-2500 / FAX 386-445-1122

PART NO.
 620-3806X

TITLE:
 SEAWARD 496 RISER HEIGHT DIMENSIONS

www.hardin-marine.com

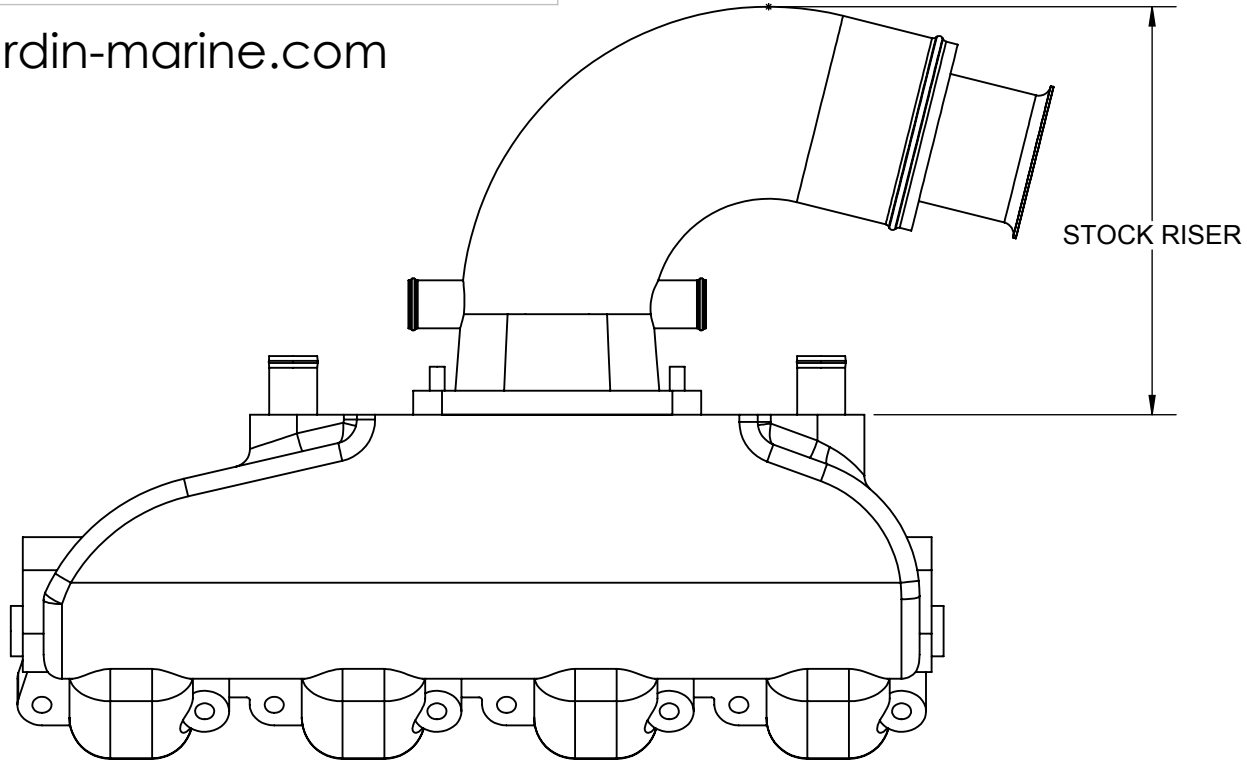

MEASURE FROM RISER FLANGE TO TOP OF RISER AS SHOWN. THE CHART BELOW SHOWS THE MERCURY HEIGHT AND THE SEAWARD KIT TO ORDER.

MERCURY RISER HEIGHT	SEAWARD KIT NUMBER	DESCRIPTION
8-1/2	620-38060	MANIFOLDS & STD HEIGHT RISERS
10-1/2	620-38061	MANIFOLDS & 2" TALLER RISERS
14-1/2	620-38062	MANIFOLDS & 6" TALLER RISERS
16-1/2	620-38063	MANIFOLDS & 8" TALLER RISERS

THIS DRAWING IS CONFIDENTIAL AND IS SUPPLIED ON EXPRESS CONDITION THAT IT SHALL NOT BE LENT, COPIED OR DISCLOSED TO ANY OTHER PERSON OR USED FOR ANY OTHER PURPOSE WITHOUT WRITTEN CONSENT OF HARDIN MARINE INC.. BREACH OF THIS CONTRACT WILL HOLD AND IT'S PRINCIPALS LIABLE FOR LOSS AND DAMAGES.