

MORSE Marine Products

Cable Adapter Kit

Part Number: 302123

For: Mercruiser Sterndrive (All Models)

Inboards

Throttle & Shift - 1975 and later

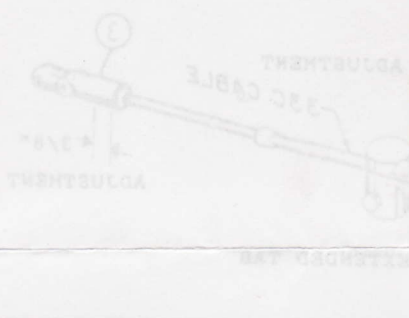

DO NOT USE ON MERCURY OUTBOARDS!

Use Only With Type 33C or 33C Supreme Morse Red-Jaket Cable

Owner's Manual

PLEASE READ THESE INTRUCTIONS THROUGH CAREFULLY AND ENTIRELY BEFORE INSTALLING OR OPERATING THIS CONTROL



Morse

Controls

Morse Controls

Hudson, Ohio

tel: 330.653.7701

fax: 330.653.7799

Installation

1. Remove the jam nut and both seals from the engine end of the cable (see Figure 1). Discard the hub seal only.

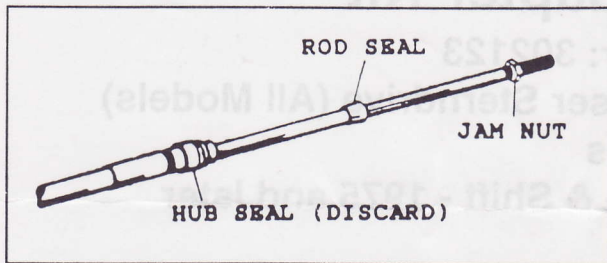

FIGURE 1

ITEM	DESCRIPTION	NUMBER REQUIRED	P/N
1	ADAPTER	2	300554
2	CLIP	2	300555
3	TERMINAL	2	033868

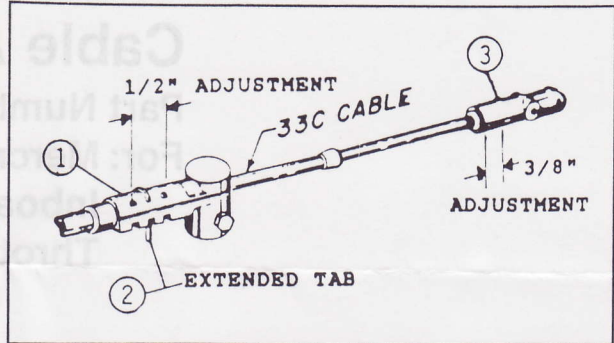

FIGURE 2

2. Slide the adapter onto the cable sleeve until a slot lines up with the cable hub groove.

NOTE:

For **shift** connection on all models, use the center slot. See Figure 3. For **throttle** connection on all models, use the slot nearest the anchor hole. See Figure 4.

3. Replace the rod seal and jam nut on the cable. Thread the terminals onto the rod for shift and throttle. The cables are now ready to be installed on the engine.

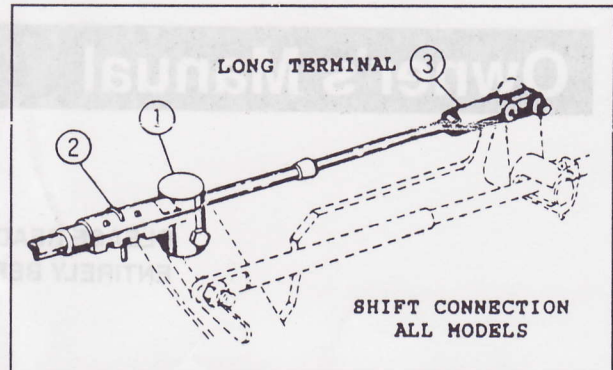

FIGURE 3

NOTE:

(For V-8 Models Only) In order to get enough throttle travel in reverse when using the Morse model "MT-3" control, the control hand lever must be placed in the vertical position at neutral detent and the cable terminal must be placed in the shorter hole on the carburetor arm.

NOTE:

After the final adjustment, lock the clip in place by **bending the extended tab of the clip over**. Do not bend over the tab until the final adjustment has been made on the engine.

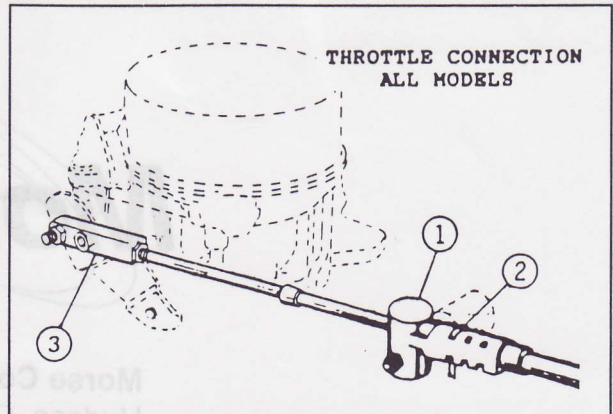

FIGURE 4

NOTE:

Follow the manufacturer's instructions for complete installation adjustments.