

MAYFAIR HYDRAULICS

PART NO.  
137-7811

TITLE:  
BILLET TRIM TANK RESERVOIR

www.mayfairperformance.com

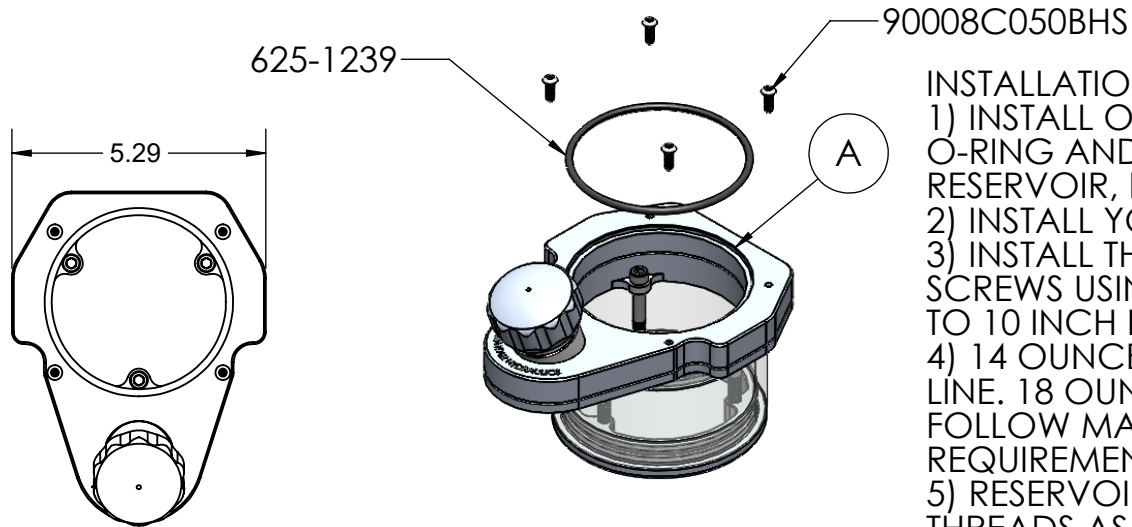

INSTALLATION INSTRUCTONS:

- 1) INSTALL OIL ON THE SUPPLIED 625-1239 O-RING AND PUT INTO GROOVE IN RESERVOIR, FIG A.
- 2) INSTALL YOUR EXISTING TRIM PUMP.
- 3) INSTALL THE (4)90008C050BS 8-32 SCREWS USING 3/32 ALLEN KEY TIGHTEN TO 10 INCH LBS..
- 4) 14 OUNCES OF FLUID TO THE COLD FILL LINE. 18 OUNCES MAX FLUID CAPACITY. FOLLOW MANUFACTURES OIL REQUIREMENTS.
- 5) RESERVOIR HAS THE SAME 3/8-16 THREADS AS THE STOCK MERCURY / MAYFAIR TRIM PUMP, SEE FIG. B.

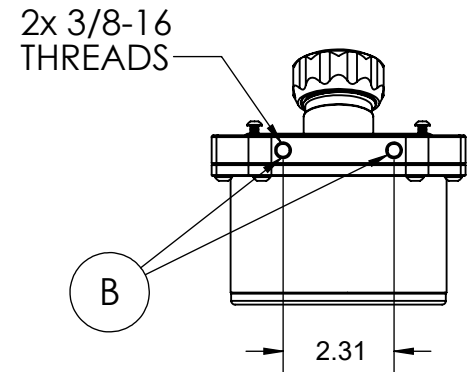
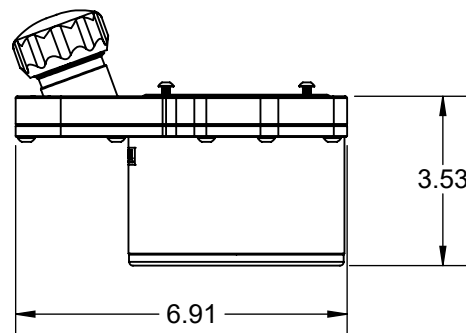
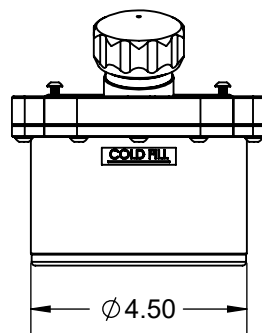

MAYFAIR HYDRAULICS

PART NO.

137-7812

TITLE: BILLET STD HEIGHT TRIM TANK RESERVOIR w/  
BULKHEAD BRACKET

[www.mayfairperformance.com](http://www.mayfairperformance.com)

INSTALLATION INSTRUCTIONS:

1) SEE 137-7814 MOUNTING INSTRUCTIONS FOR MOUNTING THE BULKHEAD BRACKET.

2) 137-7806 UPPER MOTOR SUPPORT BRACKET, FIG. A, COMES PREINSTALLED. USING A 7/16 SOCKET, REMOVE THE (2)90025C050HHS BOLTS AND WASHERS, FIG. B.

3) APPLY OIL THE SUPPLIED 625-1239 O-RING, FIG. C. INSTALL INTO THE GROOVE IN THE RESERVOIR TANK, FIG. D.

4) SLIDE THE SUPPORT BRACKET OVER THE MOTOR ON YOUR EXISTING PUMP.

5) INSTALL YOUR EXISTING PUMP USING THE SUPPLIED (4)90008C050BHS BOLTS, FIG. E, USING A 3/32 ALLEN KEY. TORQUE TO 10 INCH LBS..

6) INSTALL BOLTS BACK INTO THE MOTOR SUPPORT BRACKET. TORQUE TO 10 FT. LBS..

7) USING 5/16 ALLEN KEY TO INSTALL THE (2)90037C075SHS BOLTS, FIG. F, THROUGH THE BACK OF THE BULKHEAD BRACKET INTO THE PUMP. TORQUE TO 30 INCH LBS..

8) USING 3/16 ALLEN KEY, SNUG THE MOTOR SUPPORT CLAMP TO THE MOTOR, FIG. G. DO NOT OVER TIGHTEN.

8) INSTALL YOU EXISTING SOLENOIDS. SEE 137-7814 TO SEE HOW THEY MOUNT AND WHAT THE WIRE CODES ARE.

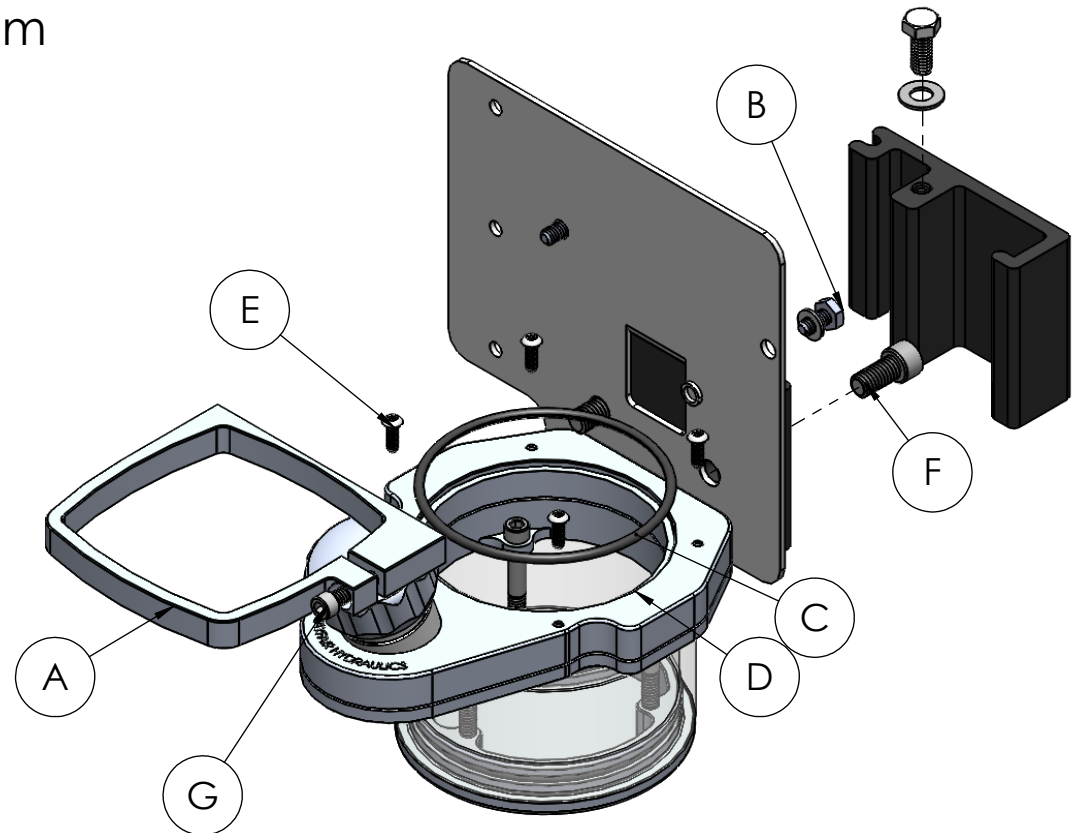

MAYFAIR HYDRAULICS

PART NO.

137-7814

TITLE: BILLET STD HEIGHT TRIM PUMP RESERVOIR  
MOUNTING INSTRUCTIONS

www.mayfairperformance.com

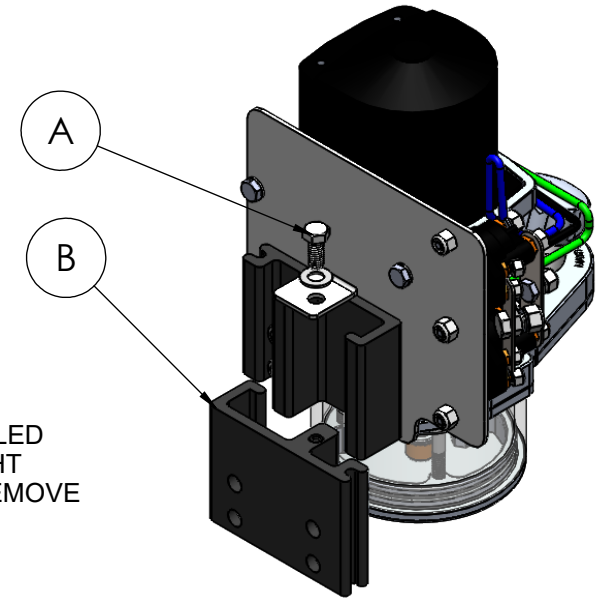
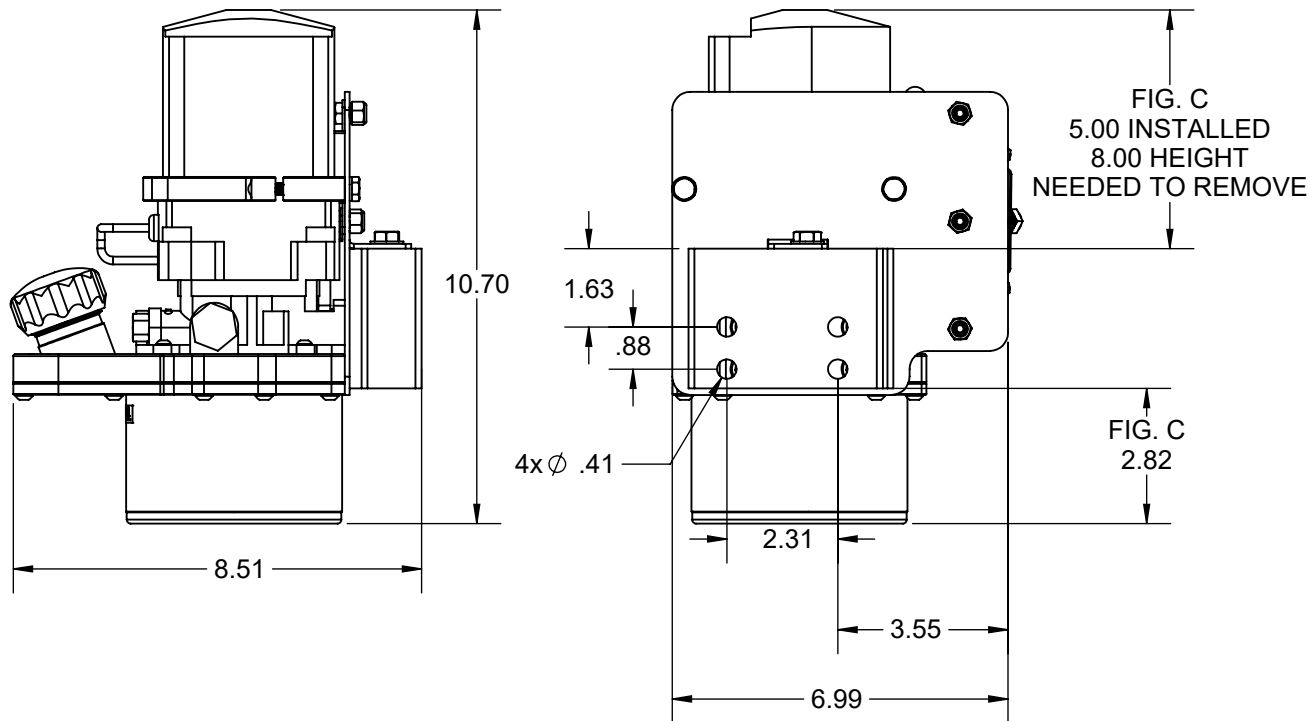

137-7814 SHOWN

#### INSTALLATION INSTRUCTIONS:

1) MOUNT TRIM PUMP IN SUCH A MANOR AS TO KEEP THEM OUT OF THE WATER FROM THE BILGE OR FROM BEING SUBMERGED OR EXPOSED TO WATER IN ANY WAY. MUST BE MOUNTED VERTICALLY, LIKE SHOWN IS DIAGRAM.

2) NO MOUNTING HARDWARE IS SUPPLIED. USE 3/8 STAINLESS LAG BOLTS OR 3/8 THRU BOLTS FOR MOUNTING.

3) TRIM PUMP COMES ASSEMBLED AS SHOWN. USING 1/2 SOCKET, REMOVE THE 5/16 BOLT AND WASHER, FIG. A. THIS WILL REMOVE BRACKET THAT MOUNTS TO THE INSTALLED AREA, FIG. B. USE THIS BRACKET TO DRILL YOU HOLES.

4) MOUNT BRACKET SO THE PUMP HAS MINIMUM 2.82 DISTANCE BELOW AND 8.00 ABOVE. SEE FIG. C.

THIS DRAWING IS CONFIDENTIAL AND IS SUPPLIED ON EXPRESS CONDITION THAT IT SHALL NOT BE LENT, COPIED OR DISCLOSED TO ANY OTHER PERSON OR USED FOR ANY OTHER PURPOSE WITHOUT WRITTEN CONSENT OF HARDIN MARINE INC.. BREACH OF THIS CONTRACT WILL HOLD ..... AND IT'S PRINCIPALS LIABLE FOR LOSS AND DAMAGES.

MAYFAIR HYDRAULICS

PART NO.  
137-7813

TITLE: BILLET STD HEIGHT TRIM TANK RESERVOIR w/  
BULKHEAD BRACKET AND SOLENOIDS

[www.mayfairperformance.com](http://www.mayfairperformance.com)

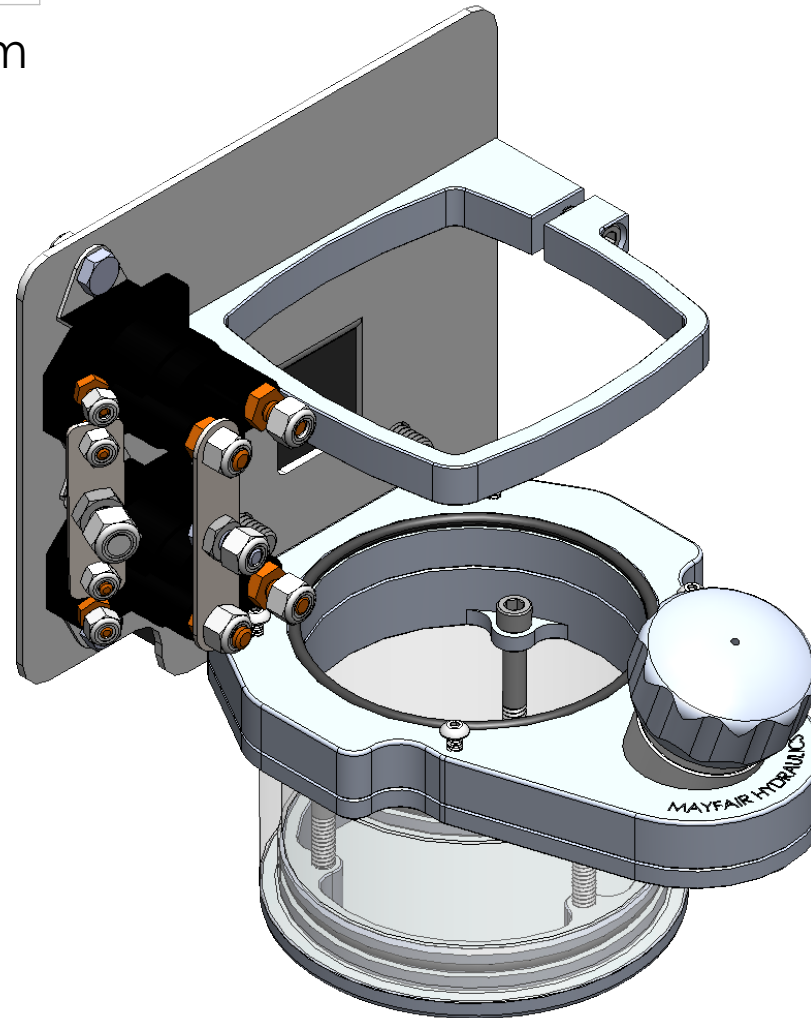

THIS DRAWING IS CONFIDENTIAL AND IS SUPPLIED ON EXPRESS CONDITION THAT IT SHALL NOT BE LENT, COPIED OR DISCLOSED TO ANY OTHER PERSON OR USED FOR ANY OTHER PURPOSE WITHOUT WRITTEN CONSENT OF HARDIN MARINE INC.. BREACH OF THIS CONTRACT WILL HOLD ..... AND IT'S PRINCIPALS LIABLE FOR LOSS AND DAMAGES.

MAYFAIR HYDRAULICS

PART NO.

137-7814

TITLE:

HARDIN TRIM PUMP w/ BILLET STD HEIGHT  
RESERVOIR, BULKHEAD MOUNT AND SOLENOIDS

[www.mayfairperformance.com](http://www.mayfairperformance.com)

### ELECTRICAL WIRING

**CAUTION** All wiring must meet  
U.S.Coast Guard Standards.

A) 10ga. red wire to positive  
battery terminal. 20 AMP fuse  
required in this line per U.S. Coast  
Guard standard.

B) 10ga. black wire to negative  
battery terminal.

C) Blue wire, trim tab - UP.

D) Green wire, trim tab -DOWN.

### CAUTION

Avoid damage to trim pump. DO  
NOT electrically operate pump  
without having hoses connected  
and 10W30 oil in the reservoir.  
Reservoir holds 14 ounces cold. 18  
ounces max fluid capacity.

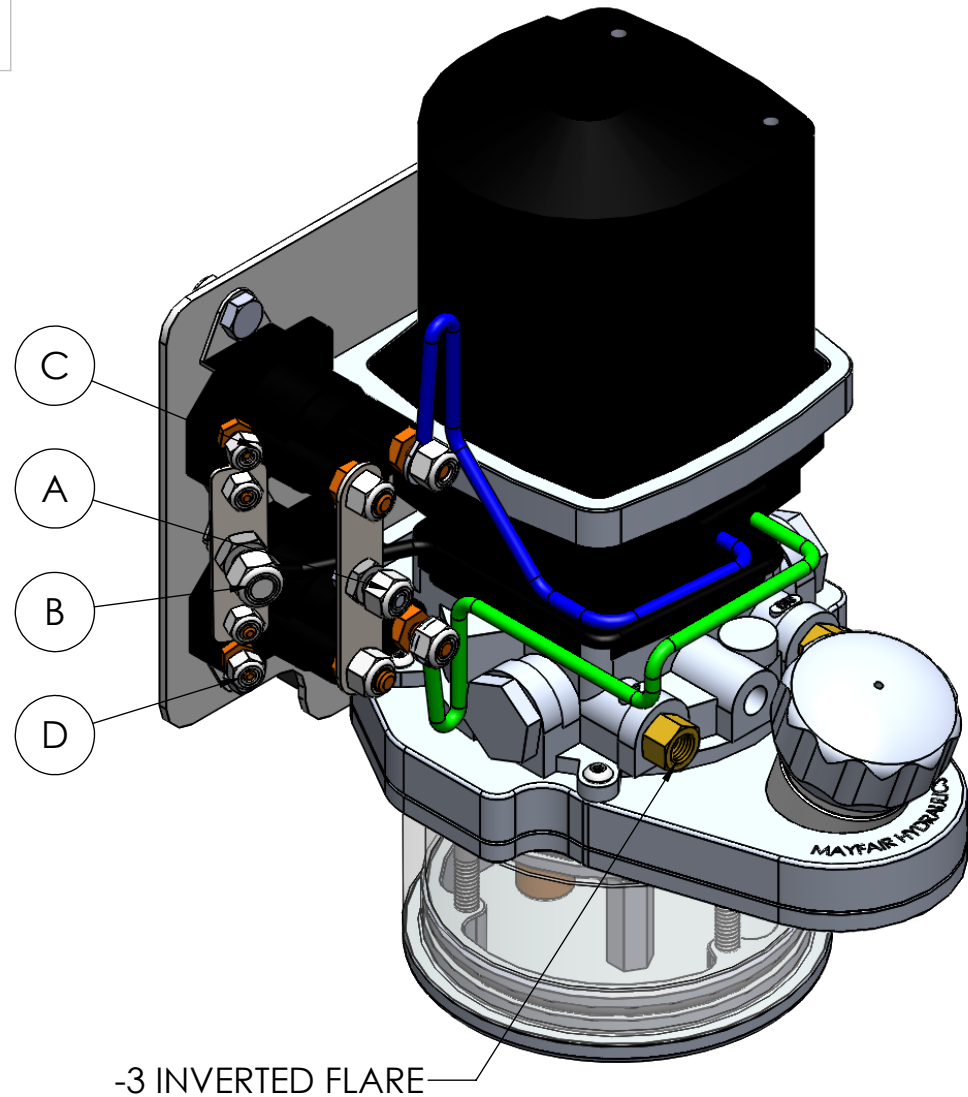

-3 INVERTED FLARE

MAYFAIR HYDRAULICS

PART NO.

137-7815

TITLE: BRAVO TRIM PUMP w/ BILLET STD HEIGHT RESERVOIR,  
BULKHEAD MOUNT & SOLENOIDS

[www.mayfairhydraulics.com](http://www.mayfairhydraulics.com)

**CAUTION**

Avoid damage to trim pump. DO NOT electrically operate pump without having hoses connected and 10W30 oil in the reservoir. Reservoir holds 14 ounces cold. 18 ounces max fluid capacity.

