



11 INDUSTRY DRIVE  
PALM COAST, FL 32137  
PHONE 877.900.7278  
FAX 386.445.1122

## **INSTALLATION INSTRUCTIONS**

### **ADD ON INSIDE COMPONENTS USING SAGINAW SHUTTLE VALVE**

#### **1. Modifying Mercury shuttle valve**

Located at the end of the Mercury directional priority valve are two external steel hydraulic lines. Remove these lines from the priority valve end only and then cut the lines at the cylinder end leaving approximately 3/4" of exposed steel line remaining.

#### **2. Installation of shuttle valve fittings and cylinder balance hose**

On the now exposed shuttle valve directional ports, install the two new adapter fittings provided in kit number (135-1070). Also provided is a 6" hose to loop between and connect the two previously cut steel lines once the cylinder is fully cycled and purged of all fluid.

#### **3. Internal hose installation**

Now the internal hoses can be installed according to the proper routing referenced in the following assembly print drawings:

Single Bravo/Single Cylinder Add On System (assembly drawing 137-9410 & 137-9413)

Single Bravo/Dual Cylinder Add On System (assembly drawing 137-9411 & 137-9414)

Dual Bravo/Dual Cylinder Add On System (assembly drawing 137-9412 & 137-9415)

**IMPORTANT:** The Left (port) and the Right (starboard) hose fittings exiting the Mercury shuttle valve are not marked. The upper fitting is the right or starboard hose and the lower fitting is the left or port hose as shown in the exploded section of the plumbing diagram. If these hoses are plumbed backwards, the system will want to slam to one side when the power steering engine is started. Upon initial start up it is suggested you have a firm grip on the steering wheel in case this situation occurs. If the wheel wants to pull in one direction these two hoses, need to be reversed.

#### **General**

All hydraulic hoses should be washed completely and blown out with compressed air before installing. Connect hoses to the hydraulic components according to the plumbing diagrams provided. Refer to STEP 2 for appropriate plumbing diagram.

## **MAYFAIR MODULAR WING PLATE & ATTACHMENT HARDWARE**

#### **1. Side link arms installation**

Remove the 4 stock studs that hold the upper gear case to the gimbal housing. Apply red loctite to the threads of the longer supplied 7/16 studs and install into the same holes as the old style studs. On the fine thread side of newly installed studs, apply anti-seize. Slide the side link arms over the studs. Thread onto the studs the locking nuts with washers.  
**DO NOT TIGHTEN THE SIDE ARMS AT THIS TIME.**

#### **2. Rear load cap installation**

Remove the 2 upper bolts of the outdrive end cap. Apply red loctite to the 3/8 bolts. Slide



11 INDUSTRY DRIVE  
PALM COAST, FL 32137  
PHONE 877.900.7278  
FAX 386.445.1122

bolts with washers into the Mayfair rear load cap. On the back side of the end, slide the spacers onto the bolts. Install the Mayfair rear load cap into the outdrive end cap. Make sure the spacers are sitting properly into the outdrive end cap. **DO NOT TIGHTEN THE BOLTS AT THIS TIME.**

**3. Side link arms to end cap installation**

Apply red loctite to the (4) 5/16 bolts. Install the bolts thru the side of side link arms to the rear load. **DO NOT TIGHTEN THE BOLTS AT THIS TIME.**

**4. Bolt torque specifications**

With all components attached. Torque the 7/16 nuts to 40 ft. lbs.. Now torque the 3/8 bolts to 30 ft. lbs. and the 5/16 bolts to 25 ft. lbs..

**General**

Detailed instructions for the installation of the Mayfair Modular Wing Plate are supplied inside the kit 137-9443.

## MAYFAIR STERNDRIVE STEERING CYLINDERS

**1. Attaching the clevis to the Mayfair Modular Wing Plate**

Install steering cylinders to the Mayfair modular wing plate with provided ½ bolt, washers and nuts. Extend steering cylinder to ½ of the cylinders allowable stroke so that the hydraulic inlet/outlet ports are facing upward and so that the transom mounting bracket is horizontal to the transom assembly. Position the stern drive gear housing so that it is straight ahead, fore and, aft and trim the out drive to its normal operating position. This can be achieved by positioning or aligning the propeller shaft parallel to the bottom of the boat.

**2. Drilling transom for bracket**

Next hold the steering cylinder mounting bracket against the transom of the boat maintaining a horizontal parallel mounting plane to the crankshaft centerline. At this point use the transom mounting plate and drilling template to identify and mark the location of the mounting holes that will be drilled in the next step. Refer to the drilling template for approximate distances in inches with the stroke of cylinder being installed. It may be helpful to use masking tape to reference the transom mounting plate location. A certain amount of variance is tolerated when necessary. The steering cylinder mounting flange area on the transom must flat, level, and solid. Always confirm that this area is free of any internal deterioration or dry rot. Always check the inside of the transom to make sure the area is free of any obstructions and proceed to drill the appropriate mounting holes.

**3. Installing the transom bracket**

Make sure and use a proper sealing material (3M 5200 sealant) when fastening the steering cylinder bracket to the transom. Slide the supplied 3/8 bolts and washers thru the bracket. Slide bolts thru the transom. Apply sealing material to the supplied backing plate. Slide backing plate over the bolt, make sure plate sits flat against the transom. Install the nuts and washers on the bolts. Torque to 30/35 ft. lbs..



11 INDUSTRY DRIVE  
PALM COAST, FL 32137  
PHONE 877.900.7278  
FAX 386.445.1122

## BLEEDING AIR FROM POWER STEERING SYSTEM

### 1. Final inspection

Before filling the system with fluid check all hose connections for tightness and proper routing according to the plumbing diagrams referenced below:

Full Hydraulic, Single Bravo/Single Cylinder (assembly print drawing 137-9410 & 137-9413)

Full Hydraulic, Single Bravo/Dual Cylinder (assembly print drawing 137-9411 & 137-9414)

Full Hydraulic, Dual Bravo/Dual Cylinder (assembly print drawing 137-9412 & 137-9415)

### 2. Bleeding the system

Fill reservoir tank 3/4 full with GM high performance power steering fluid or Valvoline synthetic power steering fluid. **IMPORTANT:** Keep reservoir tank at least half full during the bleeding process to prevent air being reintroduced into the system.

The engine containing the power steering pump must be run to properly bleed the system. Check all hose and fitting connections for any leaks while running the engine at an idle. Keep the reservoir tank 1/2 full at all times during the bleeding process. Begin to cycle the steering wheel slowly from side to side until you start to feel a hard lock out. Repeat this process until a deliberate stop occurs in both directions.

To check if the system is bled properly, align the sterndrive in the straight-ahead position and turn the engine off. Go behind the boat and manually try to move the sterndrive back and forth. If the cylinder rods move in and out, there is still air in the system. If a "slight" amount of air remains in the system this should be eliminated after the boat is run.

# HARDIN MARINE

PART NUMBER: 137-9410 & 137-9413

DESCRIPTION:  
SINGLE BRAVO/SINGLE CYLINDER ADD ON STEERING SYSTEM  
(SAGINAW SHUTTLE VALVE SYSTEM)

ITEM	QTY.	PART NO.	DESCRIPTION
1	1	SEE BELOW	COMPLETE STEERING CYLINDER ASSEMBLY
2	1	137-9443	BRAVO END CAP KIT
3	1	137-9266	SINGLE CYLINDER ADD-ON HOSE KIT

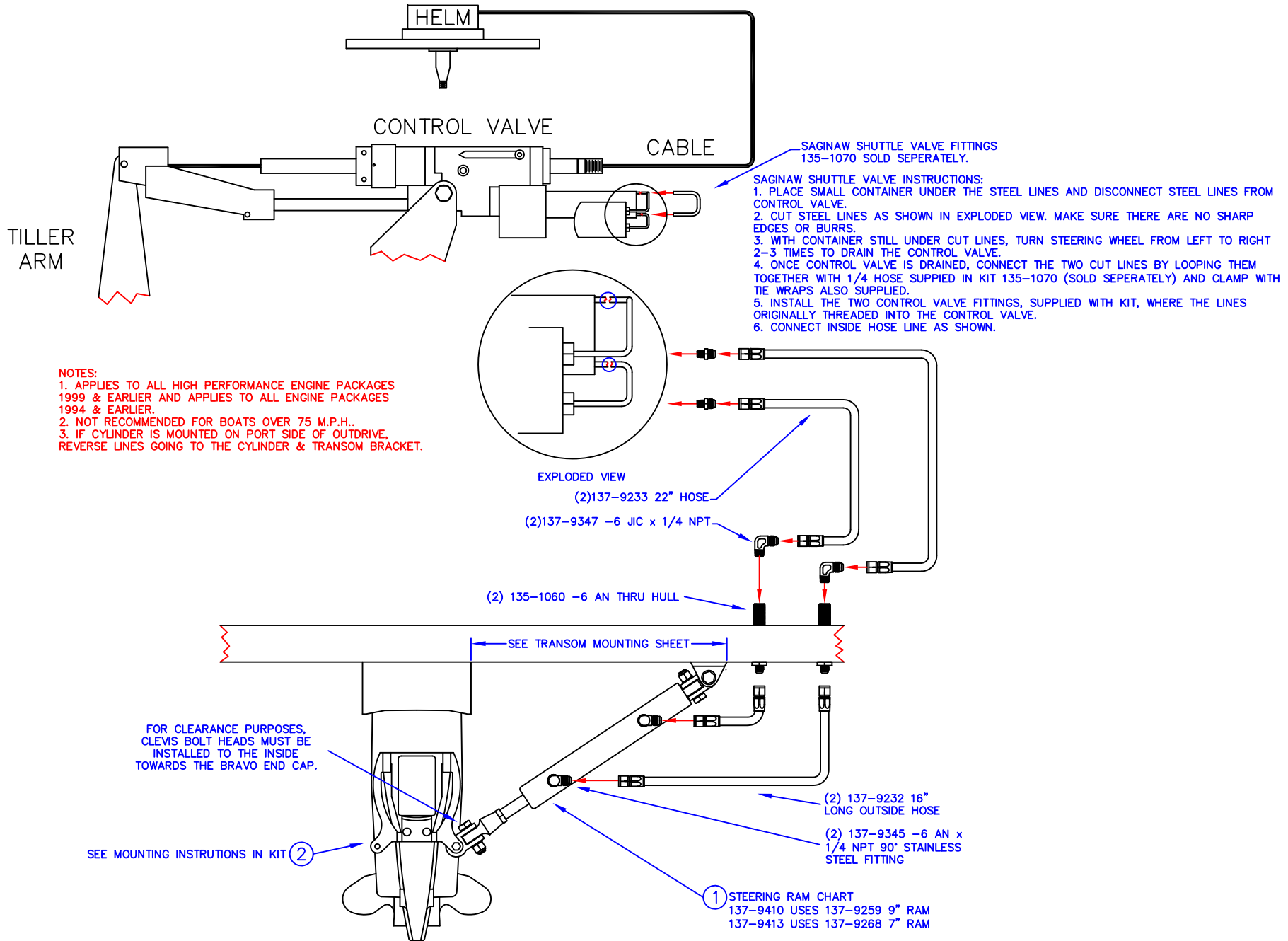

SAGINAW SHUTTLE VALVE FITTINGS  
135-1070 SOLD SEPERATELY.

SAGINAW SHUTTLE VALVE INSTRUCTIONS:  
1. PLACE SMALL CONTAINER UNDER THE STEEL LINES AND DISCONNECT STEEL LINES FROM CONTROL VALVE.  
2. CUT STEEL LINES AS SHOWN IN EXPLODED VIEW. MAKE SURE THERE ARE NO SHARP EDGES OR BURRS.  
3. WITH CONTAINER STILL UNDER CUT LINES, TURN STEERING WHEEL FROM LEFT TO RIGHT 2-3 TIMES TO DRAIN THE CONTROL VALVE.  
4. ONCE CONTROL VALVE IS DRAINED, CONNECT THE TWO CUT LINES BY LOOPING THEM TOGETHER WITH 1/4 HOSE SUPPLIED IN KIT 135-1070 (SOLD SEPERATELY) AND CLAMP WITH TIE WRAPS ALSO SUPPLIED.  
5. INSTALL THE TWO CONTROL VALVE FITTINGS, SUPPLIED WITH KIT, WHERE THE LINES ORIGINALLY THREADED INTO THE CONTROL VALVE.  
6. CONNECT INSIDE HOSE LINE AS SHOWN.

NOTES:  
1. APPLIES TO ALL HIGH PERFORMANCE ENGINE PACKAGES 1999 & EARLIER AND APPLIES TO ALL ENGINE PACKAGES 1994 & EARLIER.  
2. NOT RECOMMENDED FOR BOATS OVER 75 M.P.H..  
3. IF CYLINDER IS MOUNTED ON PORT SIDE OF OUTDRIVE, REVERSE LINES GOING TO THE CYLINDER & TRANSOM BRACKET.

# HARDIN MARINE

PART NUMBER: 137-9411 & 137-9414

DESCRIPTION:  
SINGLE BRAVO/DUAL CYLINDER ADD ON STEERING SYSTEM  
(SAGINAW SHUTTLE VALVE SYSTEM)

ITEM	QTY.	PART NO.	DESCRIPTION
1	2	SEE BELOW	COMPLETE STEERING CYLINDER ASSEMBLY
2	1	137-9443	BRAVO END CAP KIT
3	1	137-9267	DUAL CYLINDER ADD-ON KIT

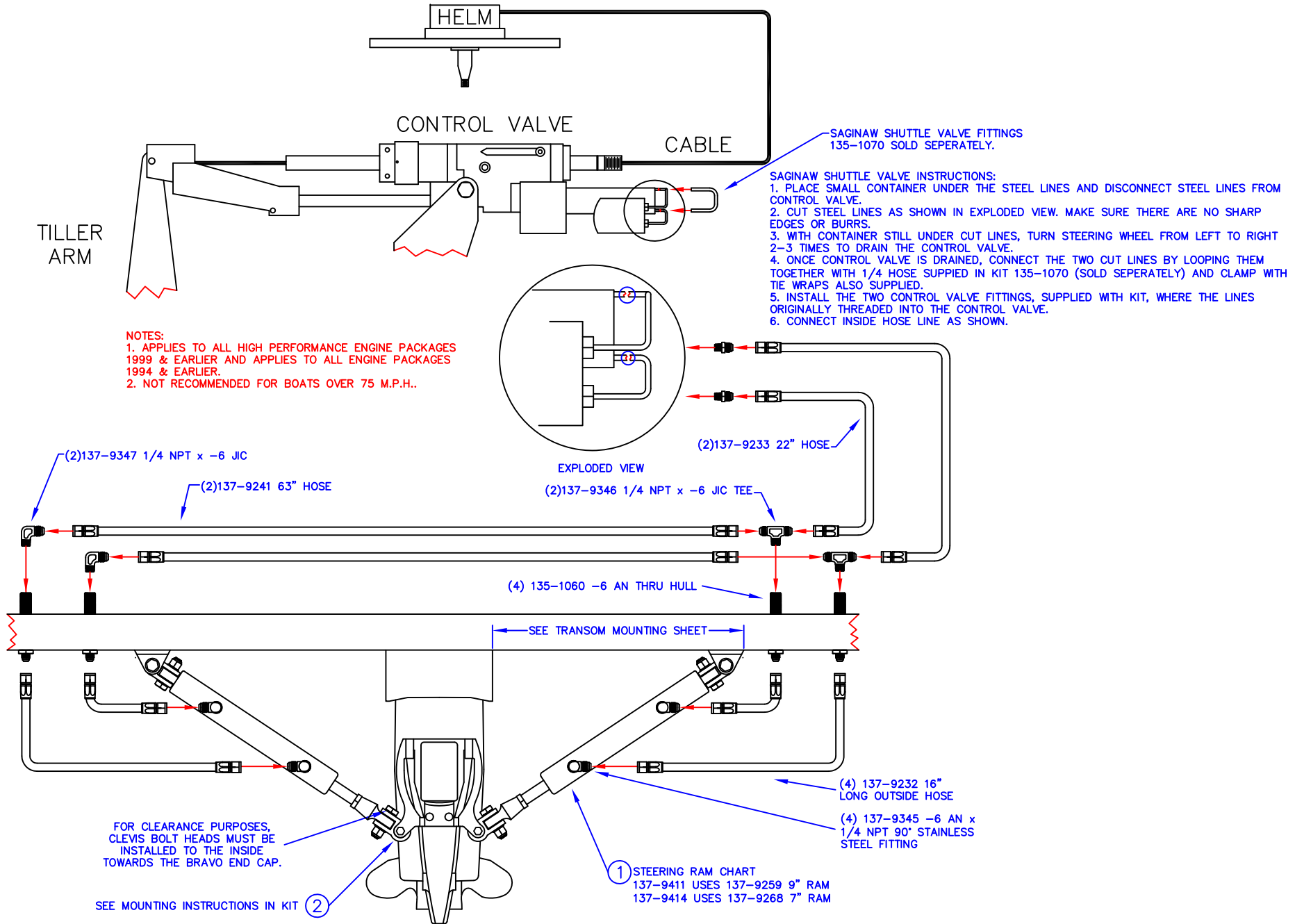

# HARDIN MARINE

PART NUMBER: 137-9412 & 137-9415

DESCRIPTION:  
DUALL BRAVO/DUAL CYLINDER ADD ON STEERING SYSTEM  
(SAGINAW SHUTTLE VALVE SYSTEM)

ITEM	QTY.	PART NO.	DESCRIPTION
1	2	SEE BELOW	COMPLETE STEERING CYLINDER ASSEMBLY
2	2	137-9443	BRAVO END CAP KIT
3	1	137-9267	DUAL CYLINDER ADD-ON KIT

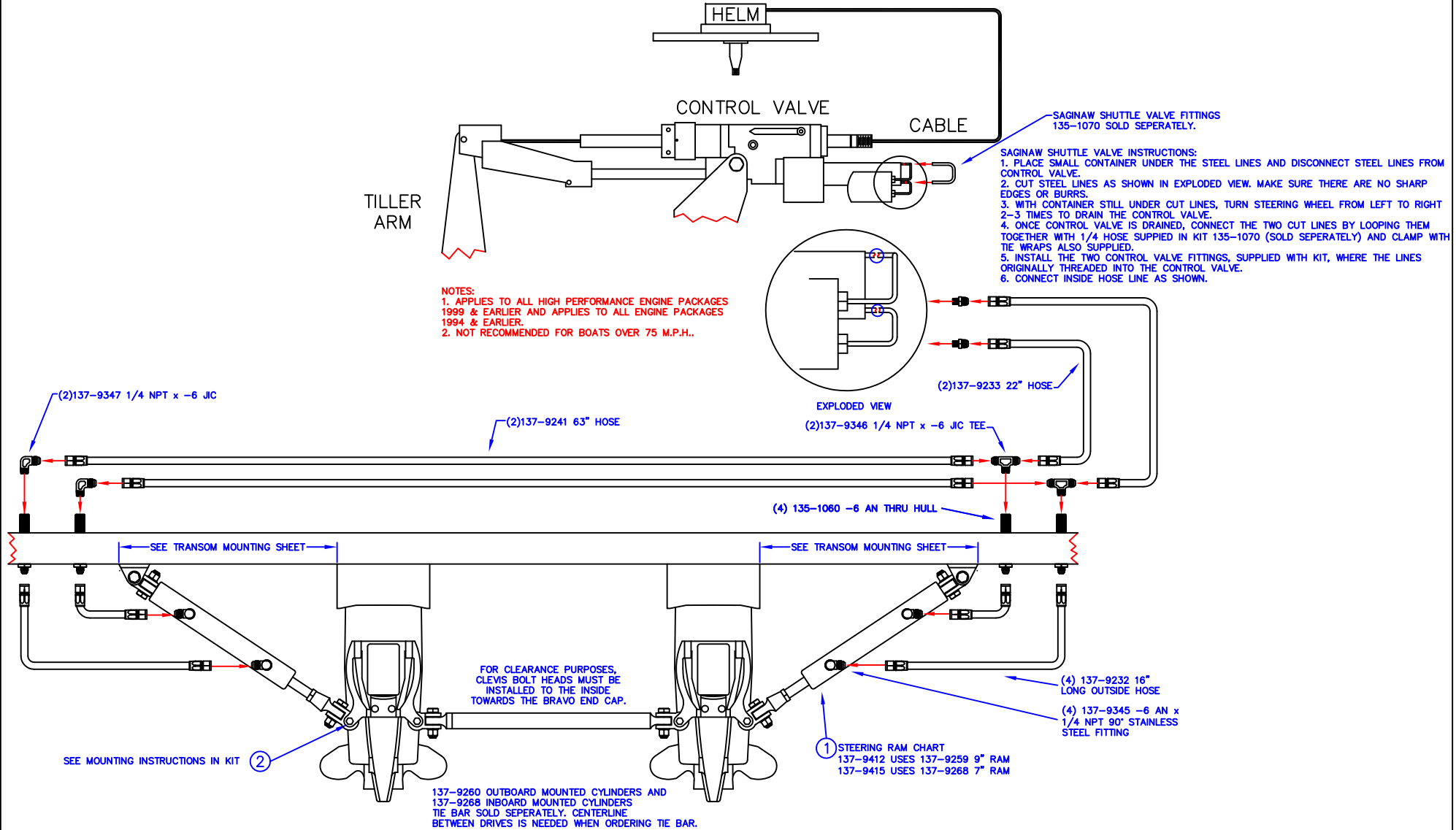

# HARDIN MARINE

PART NUMBER: TRANSOM BRACKET

DESCRIPTION:  
MAYFAIR MODULAR WING PLATE TRANSOM BRACKET MOUNTING  
LOCATION

## NOTE:

THIS PRINT IS TO SHOW THE DISTANCE THAT EACH TRANSOM BRACKET IS TO BE MOUNTED. USE THE TRANSOM BRACKET DRILL TEMPLATE & INSTALLATION INSTRUCTION SHEET THAT IS SUPPLIED IN THE STEERING RAM KIT FOR MOUNTING INSTRUCTIONS.

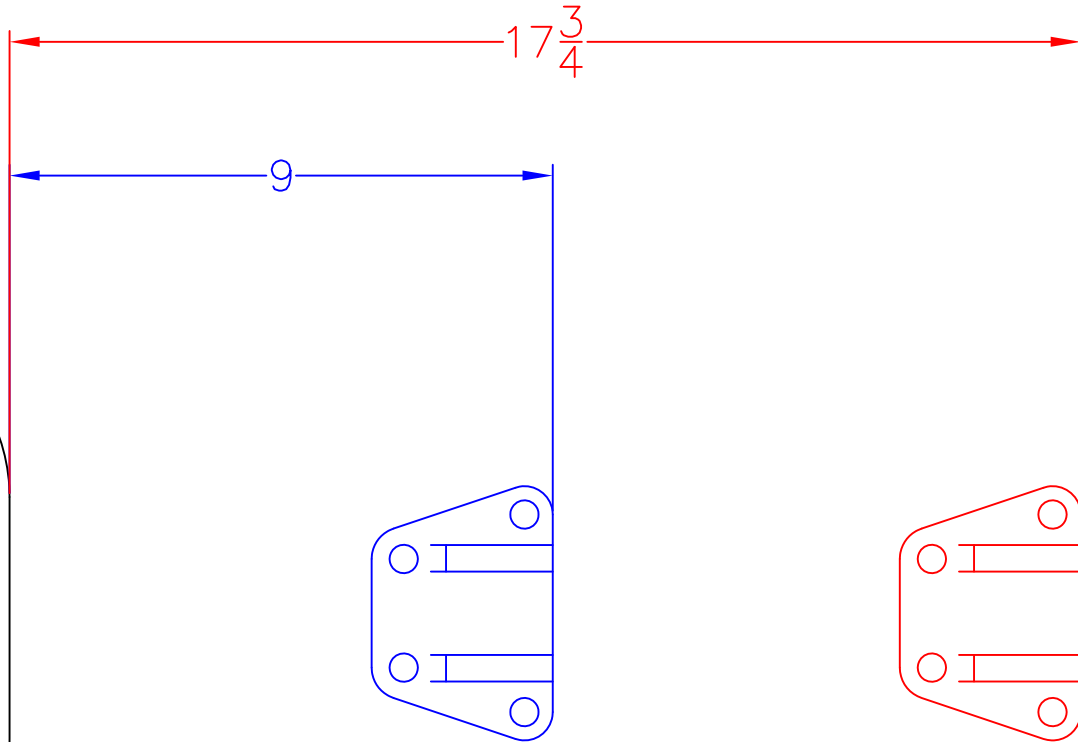
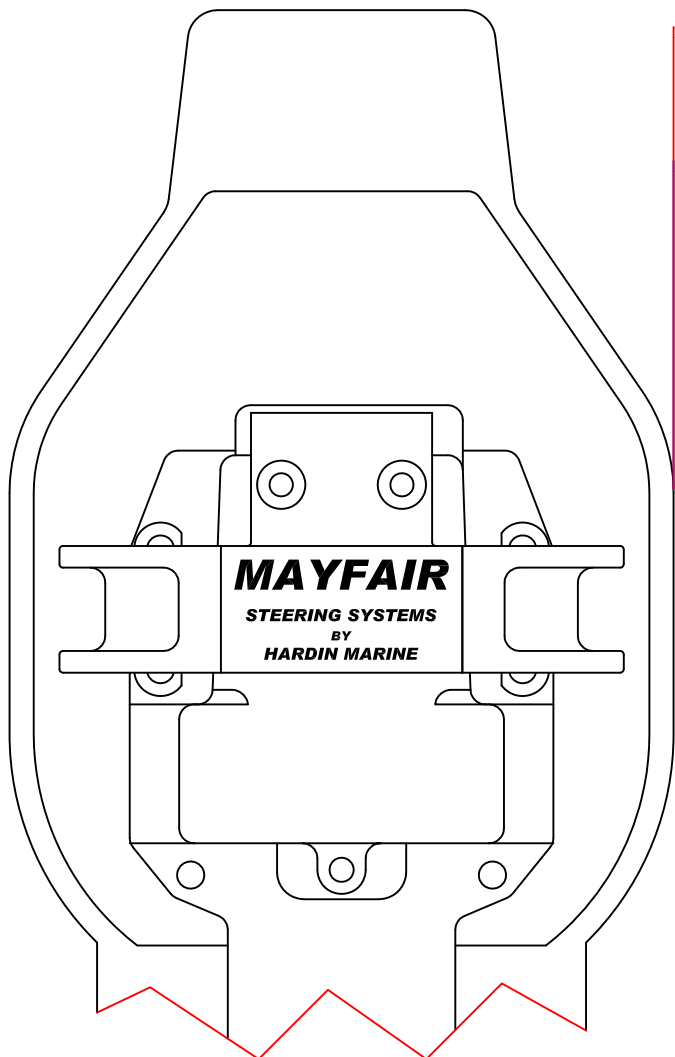

TRANSOM BRACKET  
LOCATION FOR  
137-9268 7"  
STROKE RAM

TRANSOM BRACKET  
LOCATION FOR  
137-9259 9"  
STROKE RAM