

Commander HYDRAULIC STEERING FOR OUTBOARD MOTORS

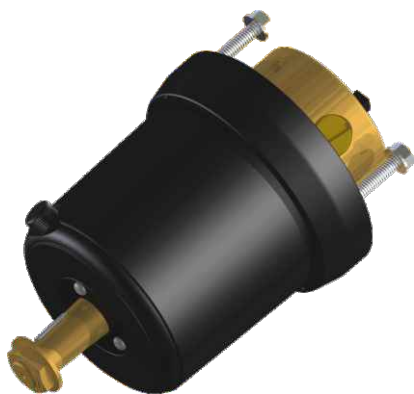

COMKIT5

For Outboards up to single 200HP or dual outboards
Counter-rotating up to 400HP total

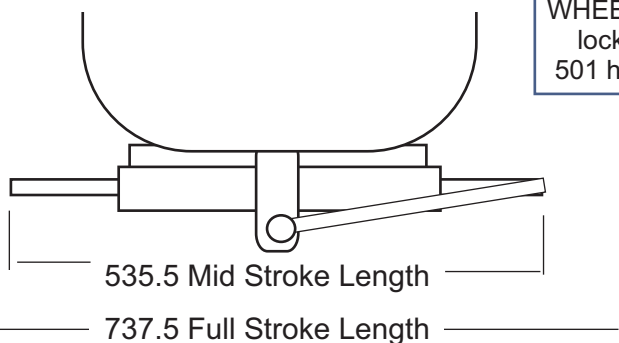

WHEEL TURNS
lock to lock
501 helm = 4.9

Model 516FM Cylinder dimensions

Capacity:- 137cc
Stroke:- 203mm
Weight:- 5Kg

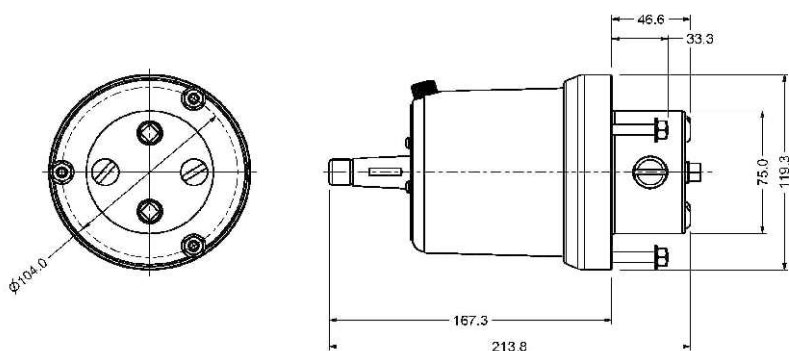

Model 501 Helm pump dimensions

Model 501 Capacity:-28cc/rev
In-built Lock valve
Maximum working pressure:- 800psi
Absolute maximum pressure:- 1000psi
Weight:- 5Kg

See also optional helm choices for front-mount
and tilting helms for this kit

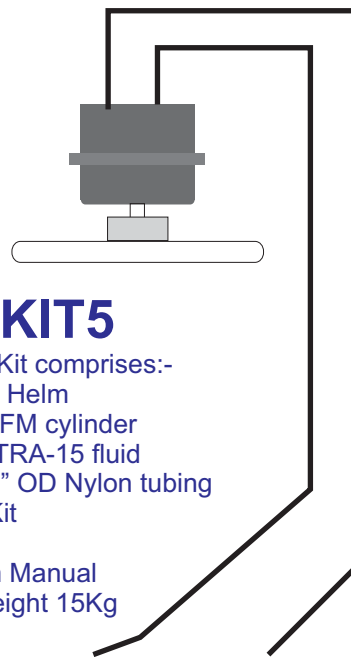

COMKIT5

Complete Kit comprises:-
Model 501 Helm
Model 516FM cylinder
2 litres ULTRA-15 fluid
15Mtrs 3/8" OD Nylon tubing
Bleeding Kit
All fittings
Installation Manual
Packed weight 15Kg

SIMPLE INSTALLATION TO ANY OUTBOARD**
See steering circuits for multiple outboards and
catamaran installation options.



HYDRIVE MODEL SELECTION - OUTBOARD MOTORS ONLY

**Note:- The model COMKIT6 can be used in place of the COMKIT1 on all SINGLE motors up to 150HP maximum.
Optimum performance range for comfortable wheel effort on COMKIT6 is 40HP - 120HP
The same version should be used as indicated in the listed options - Honda, Mercury etc.**

BRAND	YEAR	MOTOR	HP	HYDRIVE KIT OPTIONS	NOTES
JOHNSON EVINRUDE	ALL YEARS	2 Stroke Single	up to 200HP	Budget - COMKIT1 Bullhorn style Admiral-OBKIT1 Bullhorn style Budget - COMKIT5 Front-mount style Admiral- OBKIT5 Front-mount style	
		2 Stroke Single	up to 300HP	Budget - COMKIT1- PRO Bullhorn style Admiral-OBKIT1 Bullhorn style	
		2 Stroke Twin counter-rotating	up to 400HP	Budget - COMKIT1 Bullhorn style Admiral-OBKIT1 Bullhorn style Budget - COMKIT5 Front-mount style Admiral- OBKIT5 Front-mount style	
		2 Stroke Twin counter-rotating	up to 600HP	Budget - COMKIT1- PRO Bullhorn style Admiral-OBKIT1 Bullhorn style	
HONDA	PRE-2006	4 Stroke Single	75HP-90HP	Budget - COMKIT1- HONDA Bullhorn style Admiral-OBKIT1- HONDA Bullhorn style Budget - COMKIT5 Front-mount style Admiral- OBKIT5 Front-mount style	
		4 Stroke single	100HP-200HP	Budget - COMKIT1 Bullhorn style Admiral-OBKIT1 Bullhorn style Budget - COMKIT5 Front-mount style Admiral- OBKIT5 Front-mount style	Note: The 130HP requires the use of the Honda version
		4 Stroke Single	225HP	Budget - COMKIT1- PRO Bullhorn style Admiral-OBKIT1 Bullhorn style	
		4 Stroke Twin counter-rotating	up to 400HP	Budget - COMKIT1 Bullhorn style Admiral-OBKIT1 Bullhorn style Budget - COMKIT5 Front-mount style Admiral- OBKIT5 Front-mount style	Note - if using twin 75HP, 90HP or 130HP motors then Honda version required
		4 Stroke Twin counter-rotating	twin 225HP	Budget - COMKIT1- PRO Bullhorn style Admiral-OBKIT1 Bullhorn style	
	POST-2006	4-Stroke single	75-90HP	Budget - COMKIT1 Bullhorn style Admiral-OBKIT1 Bullhorn style Budget - COMKIT5 Front-mount style Admiral- OBKIT5 Front-mount style	
		4-Stroke single	115HP	Budget - COMKIT1- HONDA Bullhorn style Admiral-OBKIT1- HONDA Bullhorn style Budget - COMKIT5 Front-mount style Admiral- OBKIT5 Front-mount style	
		4-Stroke single	135HP-200HP	Budget - COMKIT1 Bullhorn style Admiral-OBKIT1 Bullhorn style Budget - COMKIT5 Front-mount style Admiral- OBKIT5 Front-mount style	
		4-Stroke single	225HP	Budget - COMKIT1- PRO Bullhorn style Admiral-OBKIT1 Bullhorn style	
		4 Stroke Twin counter-rotating	up to 400HP	Budget - COMKIT1 Bullhorn style Admiral-OBKIT1 Bullhorn style Budget - COMKIT5 Front-mount style Admiral- OBKIT5 Front-mount style	Note - if using twin 115HP motors then Honda version required
		4 Stroke Twin counter-rotating	twin 225HP	Budget - COMKIT1- PRO Bullhorn style Admiral-OBKIT1 Bullhorn style	
		4-Stroke single	30 - 40HP	Budget - COMKIT1 Bullhorn style Admiral-OBKIT1 Bullhorn style	
YAMAHA	ALL YEARS	4-Stroke single	50-70HP PLUS 80B	Budget - COMKIT1 Bullhorn style Admiral-OBKIT1 Bullhorn style Budget - COMKIT5 Front-mount style Admiral- OBKIT5 Front-mount style	Note: The transom clamps on these motors must be cut off to allow full tilt of the steering system which would otherwise interfere on the clamps. These clamps will interfere on ALL makes and brands of bullhorn or front-mount steering cylinders.
		4-Stroke single	80A-90HP PLUS 115B	Budget - COMKIT1- HONDA Bullhorn style Admiral-OBKIT1- HONDA Bullhorn style Budget - COMKIT5 Front-mount style Admiral- OBKIT5 Front-mount style	Note: The transom clamps on these motors must be cut off to allow full tilt of the steering system which would otherwise interfere on the clamps. These clamps will interfere on ALL makes and brands of bullhorn or front-mount steering cylinders.
		4-Stroke single	100-200HP	Budget - COMKIT1 Bullhorn style Admiral-OBKIT1 Bullhorn style Budget - COMKIT5 Front-mount style Admiral- OBKIT5 Front-mount style	
		4-stroke single	200-300HP	Budget - COMKIT1- PRO Bullhorn style Admiral-OBKIT1 Bullhorn style	

HYDRIVE MODEL SELECTION - OUTBOARD MOTORS ONLY

**Note:- The model COMKIT6 can be used in place of the COMKIT1 on all SINGLE motors up to 150HP maximum.
Optimum performance range for comfortable wheel effort on COMKIT6 is 40HP - 120HP
The same version should be used as indicated in the listed options - Honda, Mercury etc.**

BRAND	YEAR	MOTOR	HP	HYDRIVE KIT OPTIONS	NOTES
YAMAHA	ALL YEARS	4-stroke single	350HP	Admiral OBKIT1-HP OR OBKIT1-HP-XT	High performance unit required on 350HP
		4 Stroke Twin counter-rotating	50-70HP PLUS 80B	Budget - COMKIT1 Bullhorn style Admiral-OBKIT1 Bullhorn style Budget - COMKIT5 Front-mount style Admiral- OBKIT5 Front-mount style	<i>Note: The transom clamps on these motors must be cut off to allow full tilt of the steering system which would otherwise interfere on the clamps. These clamps will interfere on ALL makes and brands of bullhorn or front-mount steering cylinders.</i>
		4 Stroke Twin counter-rotating	80A-90HP	Budget - COMKIT1-HONDA Bullhorn style Admiral-OBKIT1-HONDA Bullhorn style Budget - COMKIT5 Front-mount style Admiral- OBKIT5 Front-mount style	<i>Note: The transom clamps on these motors must be cut off to allow full tilt of the steering system which would otherwise interfere on the clamps. These clamps will interfere on ALL makes and brands of bullhorn or front-mount steering cylinders.</i>
		4-Stroke Twin counter rotating	100-200HP	Budget - COMKIT1 Bullhorn style Admiral-OBKIT1 Bullhorn style Budget - COMKIT5 Front-mount style Admiral- OBKIT5 Front-mount style	
		4 Stroke Twin counter-rotating	200-300HP	Budget - COMKIT1-PRO Bullhorn style Admiral-OBKIT1 Bullhorn style	
		4 Stroke Twin counter-rotating	350HP	Admiral OBKIT1-HP OR OBKIT1-HP-XT	High performance unit required on 350HP
		2-Stroke single	115-200HP	Budget - COMKIT1 Bullhorn style Admiral-OBKIT1 Bullhorn style Budget - COMKIT5 Front-mount style Admiral- OBKIT5 Front-mount style	
		2-Stroke single	50-90HP	Budget - COMKIT1-MERC Bullhorn style Admiral-OBKIT1-MERC Bullhorn style Budget - COMKIT5 Front-mount style Admiral- OBKIT5 Front-mount style	<i>Note- Merc versions required on bullhorn type steering for these motors</i>
MERCURY	ALL YEARS	VERADO SINGLE	135-175HP	Budget - COMKIT1 Bullhorn style Admiral-OBKIT1 Bullhorn style Budget - COMKIT5 Front-mount style Admiral- OBKIT5 Front-mount style	
		VERADO DUAL Counter rotating	135-175HP	Budget - COMKIT1 Bullhorn style Admiral-OBKIT1 Bullhorn style Budget - COMKIT5 Front-mount style Admiral- OBKIT5 Front-mount style	
		OPTIMAX SINGLE	75-115HP	Budget - COMKIT1-MERC Bullhorn style Admiral-OBKIT1-MERC Bullhorn style Budget - COMKIT5 Front-mount style Admiral- OBKIT5 Front-mount style	<i>Note- Merc versions required on bullhorn type steering for these motors</i>
		OPTIMAX SINGLE	135-200HP	Budget - COMKIT1 Bullhorn style Admiral-OBKIT1 Bullhorn style Budget - COMKIT5 Front-mount style Admiral- OBKIT5 Front-mount style	
		OPTIMAX DUAL counter rotating	75-115HP	Budget - COMKIT1-MERC Bullhorn style Admiral-OBKIT1-MERC Bullhorn style Budget - COMKIT5 Front-mount style Admiral- OBKIT5 Front-mount style	<i>Note- Merc versions required on bullhorn type steering for these motors</i>
		OPTIMAX DUAL counter rotating	135-200HP	Budget - COMKIT1 Bullhorn style Admiral-OBKIT1 Bullhorn style Budget - COMKIT5 Front-mount style Admiral- OBKIT5 Front-mount style	
		OPTIMAX SINGLE	225HP	Budget - COMKIT1-PRO Bullhorn style Admiral-OBKIT1 Bullhorn style	
		OPTIMAX DUAL counter rotating	225HP	Budget - COMKIT1-PRO Bullhorn style Admiral-OBKIT1 Bullhorn style	
		4-Stroke single	60-115HP NEW 150HP USES STANDARD ARM	Budget - COMKIT1-MERC Bullhorn style Admiral-OBKIT1-MERC Bullhorn style Budget - COMKIT5 Front-mount style Admiral- OBKIT5 Front-mount style	<i>Note- Merc versions required on bullhorn type steering for these motors - Except new 150HP uses standard tiller arm</i>

HYDRIVE MODEL SELECTION - OUTBOARD MOTORS ONLY

Note:- The model COMKIT6 can be used in place of the COMKIT1 on all SINGLE motors up to 150HP maximum.
Optimum performance range for comfortable wheel effort on COMKIT6 is 40HP - 120HP
The same version should be used as indicated in the listed options - Honda, Mercury etc.

BRAND	YEAR	MOTOR	HP	HYDRIVE KIT OPTIONS	NOTES
MERCURY	ALL YEARS	4-Stroke DUAL Counter rotating	60-115HP - see above for 150HP	Budget - COMKIT1- MERC Bullhorn style Admiral-OBKIT1- MERC Bullhorn style Budget - COMKIT5 Front-mount style Admiral- OBKIT5 Front-mount style	Note- Merc versions required on bullhorn type steering for these motors - Except new 150HP uses standard tiller arm
		2-Stroke single	40-200HP	Budget - COMKIT1 Bullhorn style Admiral-OBKIT1 Bullhorn style Budget - COMKIT5 Front-mount style Admiral- OBKIT5 Front-mount style	
		2-Stroke single	EFI 250HP	Budget - COMKIT1- PRO Bullhorn style Admiral-OBKIT1 Bullhorn style	
		2-Stroke single	40-90HP	Budget - COMKIT1 Bullhorn style Admiral-OBKIT1 Bullhorn style Budget - COMKIT5 Front-mount style Admiral- OBKIT5 Front-mount style	
		2-Stroke single	Bigfoot 40-60HP	Budget - COMKIT1 Bullhorn style Admiral-OBKIT1 Bullhorn style Budget - COMKIT5 Front-mount style Admiral- OBKIT5 Front-mount style	
		2-Stroke DUAL Counter rotating	40-200HP	Budget - COMKIT1 Bullhorn style Admiral-OBKIT1 Bullhorn style Budget - COMKIT5 Front-mount style Admiral- OBKIT5 Front-mount style	
		2-Stroke DUAL Counter rotating	EFI 250HP	Budget - COMKIT1- PRO Bullhorn style Admiral-OBKIT1 Bullhorn style	
		2-Stroke DUAL Counter rotating	40-90HP	Budget - COMKIT1 Bullhorn style Admiral-OBKIT1 Bullhorn style Budget - COMKIT5 Front-mount style Admiral- OBKIT5 Front-mount style	
		2-Stroke DUAL Counter rotating	Bigfoot 40-60HP	Budget - COMKIT1 Bullhorn style Admiral-OBKIT1 Bullhorn style Budget - COMKIT5 Front-mount style Admiral- OBKIT5 Front-mount style	
SUZUKI	ALL YEARS	4-stroke single	40-140HP	Budget - COMKIT1 Bullhorn style Admiral-OBKIT1 Bullhorn style Budget - COMKIT5 Front-mount style Admiral- OBKIT5 Front-mount style	Note: some older models may require a spacer to fit into the recess under the tiller arm. These are available on request. Current motors do not require them.
		4-Stroke single	150-200HP	Budget - COMKIT1 Bullhorn style Admiral-OBKIT1 Bullhorn style Budget - COMKIT5 Front-mount style Admiral- OBKIT5 Front-mount style	
		4-Stroke single	225-250HP	Budget - COMKIT1- PRO Bullhorn style Admiral-OBKIT1 Bullhorn style	
		4-Stroke DUAL Counter rotating	40-140HP	Budget - COMKIT1 Bullhorn style Admiral-OBKIT1 Bullhorn style Budget - COMKIT5 Front-mount style Admiral- OBKIT5 Front-mount style	Note: some older models may require a spacer to fit into the recess under the tiller arm. These are available on request. Current motors do not require them.
		4-Stroke DUAL Counter rotating	150-200HP	Budget - COMKIT1 Bullhorn style Admiral-OBKIT1 Bullhorn style Budget - COMKIT5 Front-mount style Admiral- OBKIT5 Front-mount style	
		4-Stroke DUAL Counter rotating	225-250HP	Budget - COMKIT1- PRO Bullhorn style Admiral-OBKIT1 Bullhorn style	
TOHATSU	ALL YEARS	SINGLE	60-90HP	Budget - COMKIT1- MERC Bullhorn style Admiral-OBKIT1- MERC Bullhorn style Budget - COMKIT5 Front-mount style Admiral- OBKIT5 Front-mount style	Note- Merc versions required on bullhorn type steering for these motors
		SINGLE	100-200HP	Budget - COMKIT1 Bullhorn style Admiral-OBKIT1 Bullhorn style Budget - COMKIT5 Front-mount style Admiral- OBKIT5 Front-mount style	
		DUAL Counter rotating	60-90HP	Budget - COMKIT1- MERC Bullhorn style Admiral-OBKIT1- MERC Bullhorn style Budget - COMKIT5 Front-mount style Admiral- OBKIT5 Front-mount style	Note- Merc versions required on bullhorn type steering for these motors
		DUAL Counter rotating	100-200HP	Budget - COMKIT1 Bullhorn style Admiral-OBKIT1 Bullhorn style Budget - COMKIT5 Front-mount style Admiral- OBKIT5 Front-mount style	