

Whipple Superchargers 93'-01' 454/502 Magnum Installation Instructions



**Version A1R9
Last Updated April 1st, 2010**

MUST KNOW INFORMATION!!

-EVERYBODY READ!!-

WATER FLOW – WATER FLOW – WATER FLOW

As of May 2002, Mercury Racing issued a service bulletin (attached to instructions) regarding engine water block pressure. In this bulletin, it's clear that Mercury Racing requires a minimum of 20-30lbs. of engine water pressure at wide-open throttle (WOT). If this pressure is not achieved or not maintained, you can have catastrophic engine failure of many types.

This leads us to your new supercharged engine. You're no longer running a thermostat in the engine, which was the largest water restriction in the stock system. Now, the largest restriction is the engine itself, this means pressure is only increased by flow in this given application. Because you are taking your stock engine and increasing the cylinder pressure for more peak power, to insure reliability, you need **more** water to keep the engine cool and at the same time, you need **more** water pressure to keep steam pockets from developing in your engine. With this in mind, you want a minimum of 25lpsi of block pressure @ WOT, maximum 40psi @ WOT. If you do not have this pressure, you may hurt your engine.

Whipple Superchargers has provided a stainless restrictor for the thermostat housing that will restrict the flow like a thermostat, but pressure still must be checked, as this may be too much restriction (ideally) or not enough (means you need more). With this information in mind, you must understand, you must have more flow as well as pressure, if you restrict the outlet water too much and don't have proper flow, you will heat the engine up, still develop steam pockets and it could lead to engine failure.

- Ideally, the intercooler should be fed from a separate source. The intercooler does not need constant water flow at slow speeds. This means a separate pickup can be installed solely for the intercooler.
- You can run the intercooler off the drive side draft inlets, but never the engine.
- Mercury dual style water pickups do not let more water in, in fact, they have less water flow. Always block off the side draft inlets if your boat uses them on this dual style drives.
- Never run the engine off side draft inlets in the drive, never!
- If you have a stepped bottom or high "X" dimension, water flow may be very low at high speeds and caution must be taken.
- Test block pressure at various trim angles and in turns.
- Lower boost and or timing does not mean you're safer with less water, if steam develops, the engine will fail regardless, it needs pressure to push the steam out.

WATER FLOW – WATER FLOW – WATER FLOW

WHIPPLE CHARGER INSTALLATION INSTRUCTIONS 454/502 MAGNUM MPI STAGE 1

This product is intended for use on **STOCK, UNMODIFIED, WELL-MAINTAINED ENGINES**. Installation on a worn-out engine is not recommended and could result in failure of the engine or the supercharger. It is recommended to perform a compression test of all cylinders, and perform a cylinder pressure leak down procedure, check and change spark plugs, spark plug wires, distributor cap, and rotor if necessary. This will indicate the condition of the engine for reference. Whipple also recommends accurate fuel pressure and water block pressure gauges for constant monitoring during operation.

This system is designed around the Delphi MEFI 3 and 4 ECM systems. If you have a MEFI 1, you will need a new ECM and you'll have to modify the harness at the end of the instructions. It's a good idea to review this as you may want to modify this during the middle of the installation.

It is the purchaser's responsibility to follow all installation instruction guidelines and safety procedures supplied with the product as it is received by the purchaser to determine the compatibility of the product with the vessel or the device the purchaser intends to install the product on.

Whipple Supercharger assumes no responsibility for damages occurring from accident, misuse, abuse, improper installation, improper operation, lack of reasonable care, or all previously stated reasons resulting from incompatibility with other manufacturers' products.

****NOTICE:** Installation of Whipple Supercharger products signifies that you have read this document and have agreed to the terms stated within.

It is the purchaser's responsibility to follow all installation instruction guidelines and safety procedures supplied with the product as it is received by the purchaser to determine the compatibility of the product with the vessel or the device the purchaser intends to install the product on.

Whipple Supercharger assumes no responsibility for damages occurring from accident, misuse, abuse, improper installation, improper operation, lack of reasonable care, or all previously stated reasons resulting from incompatibility with other manufacturers' products.

There are no warranties expressed, implied, for merchantability or fitness for engine failure, parts failure, any type of damage to vessel in any way, or reimbursement for labor or inconvenience.

YOU MUST SEND YOUR ECU IN FOR REPROGRAMMING TO WORK WITH THE WHIPPLE SUPERCHARGER SYSTEM. THERE ARE REPLACEMENT ECU'S AVAILABLE. ACCOMPANY EACH COMPUTER WITH NAME, SHIPPING INFORMATION, CONTACT INFO, BOAT INFO AND IF ANY MODIFICATIONS HAVE BEEN MADE TO THE ENGINE. WHIPPLE WILL PAY FOR STANDARD GROUND FREIGHT IN THE CONTINENTAL U.S. IF YOU WANT FASTER SERVICE OR SHIPPING FROM FROM OUTSIDE THE CONTINENTAL U.S., PROVIDE PAYMENT INFORMATION FOR FREIGHT. SEND FACTORY ECU TO:

WHIPPLE SUPERCHARGERS
ATTENTION: MARINE ECU RECAL DEPARTMENT
3292 N. WEBER
FRESNO, CA 93722
559.442.1261

For best performance and continued reliability the following are **MANDATORY**.

1. USE ONLY PREMIUM GRADE FUEL (91 OCTANE OR BETTER). NEVER USE LOWER OCTANE.
2. ALWAYS LISTEN FOR ANY SIGN OF ENGINE KNOCKING, IF PRESENT DISCONTINUE USE IMMEDIATELY.
3. DO NOT OPERATE ENGINE IN BOOST IF THE FUEL PRESSRUE IS BELOW THE PRESSURE SPECIFIED BY WHIPPLE INDUSTRIES.
4. NEVER CHANGE THE WHIPPLE COMPUTER CALIBRATION PROGRAM (ENGINE RUN FUEL, IGNITION TIMING OR THE RPM LIMITER, NOTHING!) THIS COMPLETE SUPERCHARGER SYSTEM IS DESIGNED AND ENGINEERED TO MAXIMUM PERFORMANCE FROM THE WHIPPLE CALIBRATION. ANY MODIFICATIONS TO PROGRAM MAY CAUSE SERIOUS DAMAGE TO THE ENGINE.

WARNING! The most important precaution you must take with the WHIPPLE CHARGER is cleanliness. This supercharger is a high quality, close tolerance compressor that cannot be subjected to dirt or any type of foreign material. Foreign material entering the supercharger will automatically void all warranties. **DO NOT** remove the protective seal on the supercharger prior to installation.

This system requires a major fuel system modification. Use extreme caution around the high flammable fuel and fuel vapors.

Always wear appropriate safety goggles and gloves when required.

Always use caution around flammable liquids.



SYSTEM PERFORMANCE INFORMATION

A Mercruiser scanner is an electronic tool used to display various engine parameters. This scanner can be installed and monitor all engine parameters while the boat is being operated. Some of these are items are: RPM, TPS volts, KNOCK RETARD, COOLANT temp, IAC counts, and any TROUBLE CODES. You can also put the engine in the set timing mode. You can purchase this scanner at Whipple Industries for \$600.

1. **TPS Voltage Setting**- Before starting your engine, you must set the TPS voltage utilizing a MerCruiser scan tool or a standard 0-5v volt meter. The proper TPS voltage is between .50 - .55 volts. The TPS is a 5v sensor. The blue wire is the signal wire.

2. **Idle speed setting**- Your modified ECU has a "desired" idle speed that varies with engine temp. The engine should idle at approx. 800rpm @ 75° and 725rpm @ 100°. The ECU will modify both spark timing and the IAC position (counts). These numbers will constantly vary to maintain a smooth idle in and out of gear. If you have a scan tool, timing should bounce in the positive range, approx. 0-16, if it's constantly lower, it needs more air. If it's constantly higher (in neutral), then it needs less air. For the IAC counts, 150 is max wide open meaning that its allowing as much air into the system as possible, while 0 counts means the IAC is closed, it is not allowing air into the system. If the counts are to low, adjust the closed throttle stop to close the throttle. If the counts are to high, adjust the throttle to open more. Although this number will move, in neutral, you want it to start high when engine fires and then count down to 0-40 counts. This will allow it to open to max when engine is shifted into gear. *Note: The engine must be turned off for 5 seconds and re-started to properly reset the learning of the IAC system.*

IDLE AIR CONTROL (IAC) VALVE

The purpose of the IAC valve assembly is to control engine idle speed, while preventing stalls due to changes in engine load. The IAC valve, mounted on the throttle body, controls bypass air around the throttle valves.



72800

Moving a pintle IN, toward the seat (to decrease air flow), or OUT, away from the seat (to increase air flow), controls the amount of air moving around the throttle valve. If rpm is too low, more air is bypassed around the throttle valve to increase it. If rpm is too high, less air is bypassed around the throttle valve to decrease it.

The ECM moves the IAC valve in small steps, called counts. These can be measured by scan tool test equipment, which plugs into the DLC connector.

During idle, the proper position of the IAC valve is engine load, and engine rpm. If the rpm drops below specification and the throttle valve is closed, the ECM senses a near stall condition and calculates a new valve position to prevent stalling.

- Engine idle speed is a function of total air flow into the engine based on IAC valve pintle position.
- "Controlled" idle speed is programmed into the ECM, which determines the correct IAC valve pintle position to maintain the desired idle speed for all engine operating conditions and loads.
- The minimum idle air rate is set at the factory with stop screws. This setting allows enough air flow by the throttle valves to cause the IAC valve pintle to be positioned a calibrated number of steps (counts) from the seat during "controlled" idle operation.
- If the IAC valve is disconnected and reconnected with the engine running, the idle speed may be wrong. In this case, the IAC valve can be reset by doing the following: Turn off engine, wait ten seconds, and restart engine.

3. Check cooling system water pressure. The cooling system must be able to operate efficiently. Optimal performance and reliability will be gained if an external pick-up is installed for the Whipple Intercooler water. To check the performance of your cooling system, install a 0-50psi. pressure gauge on the water drain plug located on the bottom center of the block. The idle pressure may read 0-3psi. and full speed/RPM may read over 30psi. The minimum pressure allowed, for proper engine cooling, is 30psi at WOT. 40psi should be the maximum, if exceeded, please contact Whipple Industries. The reading should be obtained at high speed and high RPM. If the pressure is lower, another water pickup must be installed. Consult with Whipple Industries for recommendations. The Whipple intercooler will take water away from the engine if the water is teed from the stock system, so block pressure must be checked before and after.

4. MEFI Engine management system. If your engine has a MEFI 1 ECM, your system must be updated to a MEFI 3 or 4 system. Follow the wire diagram at the end of the manual for converting.

4. Supercharger By-pass system. The supercharger is installed with a by-pass system. This allows the supercharger to operate at higher efficiency under vacuum operation. It is advised to verify the operation of the bypass valve. At idle and low engine loads, the bypass will be open. At higher loads (engine in boost) the bypass will be closed. As the throttle is opened quickly the bypass valve will close momentarily. This verifies the bypass will close and is functioning.

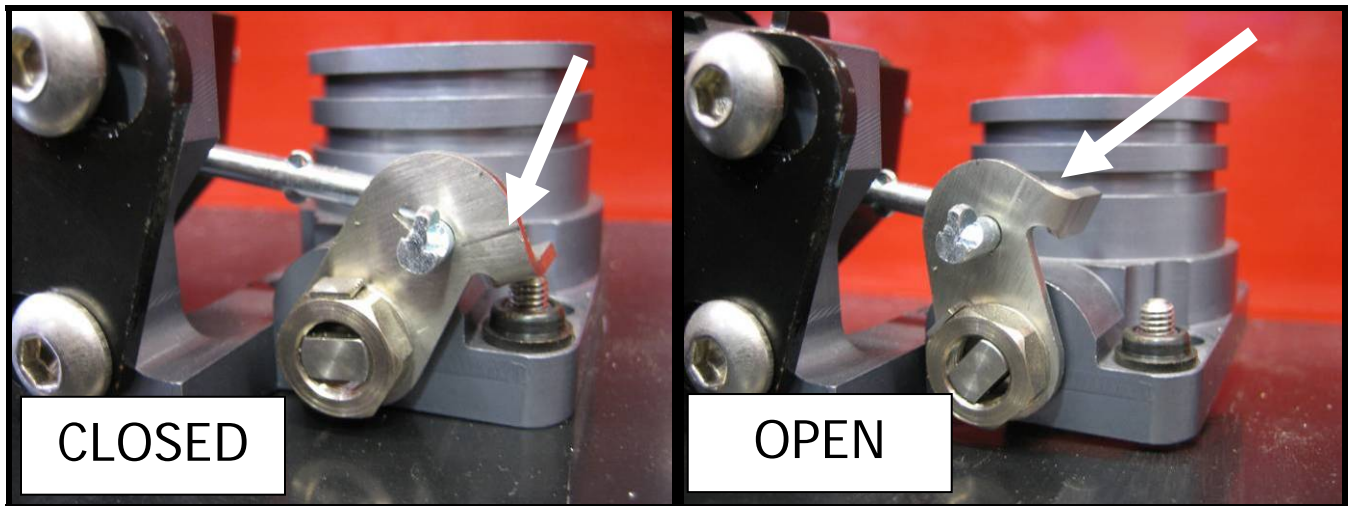

1. Move actuator arm into actuator.
 2. Plug top port with finger while actuator is pressed in.
 3. Let go of actuator arm while finger is still on top port.
 4. If actuator is good, actuator arm will stay in the same position until you remove your finger. If bad, it will come back to it's relaxed position.
- IF BAD, REPLACE IMMEDIATELY

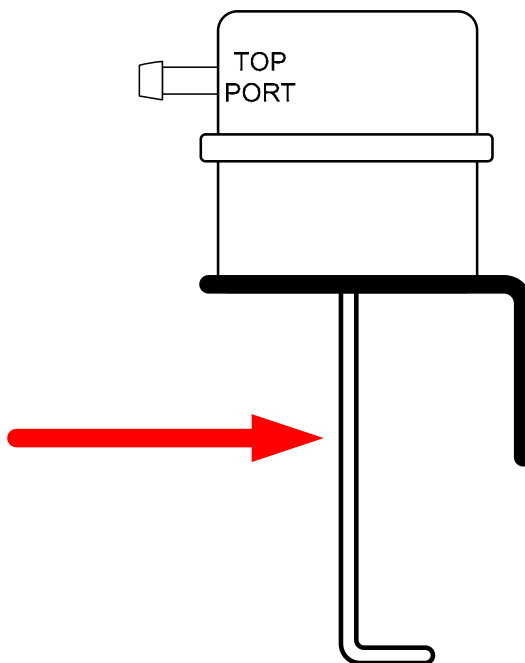

SYMBOL KEY

Throughout this installation guide you will see the following symbols used:

NOTE

Used to indicate tips and information to aid in installation, maintenance, or use of the supercharger.

!! CAUTION !!

Used to indicate precautions that must be taken to avoid damage to the supercharger and associated components.

⚠ WARNING!!

*Used to indicate precautions that must be taken to avoid **bodily injury** as well as **damage to the supercharger and associated components.***

COMMON ABBREVIATIONS

SC	Supercharger
PSI	Pressure
ECT	Engine Coolant Temperature
IAT	Inlet Air Temperature
IAC	Idle Air Control
TPS	Throttle Position Sensor
MAP	Manifold Absolute Pressure
PCV	Positive Crankcase Ventilation

**WARNING!! CONSTANT ABUSE OF THE REV
LIMITER WILL CAUSE SEVERE ENGINE
FAILURE!!**

STEP-BY-STEP INSTALLATION INSTRUCTIONS

1. Disconnect the battery power by selecting the disconnect mode on the battery switch or removing the ground cable from all batteries.
2. Removal of stock parts:
 - (SERP)** Loosen the stock adjustable idler nut to release tension of belt, remove the stock belt.
 - (VBELT)** Loosen accessories and remove factory v-belts.
 - Remove the factory crank pulley and clean the front surface, the new SC crank pulley will mount to the surface of this later.
 - Unplug factory electrical plugs: Idle Air Control connector, Inlet Air Temp connector, both Engine Coolant Temp connectors, Manifold Absolute Pressure connector, both distributor connectors.

- Remove stock throttle linkage and throttle body (throttle cable bolt and IAC motor) and flame arrestor.
- Remove factory shift cable bracket and mount on transom.
- Loosen the belt tensioner holding nut. Release the tension on the Poly-V belt and remove belt.
- Remove the self-locking nut and washer holding throttle cable to the throttle shaft and washer.
- Install stock IAC motor on new throttle body with stock o-rings and stock torx.
- Remove PCV valve and hose from intake manifold/valve cover.
- Remove the distributor (replace if more than 100 hours or 2 seasons, only use Mercury Marine distributors, other aftermarket replacements are not compatible with the MEFI system). **Note:** It helps to mark the position of the distributor before removal so it can be stabbed much closer to 8 degrees. You can take the distributor cap off, crank engine over until pointer faces directly forward or scribe a mark on the distributor housing marking the position of the rotor.
- Remove MerCruiser fuel lines from stock fuel filter assembly (leave your factory line routed to filter from tank).
- Remove factory fuel lines and unplug factory fuel pump. Leave cool fuel unit in place.
- Inspect factory fuel line from tank. Make sure there are no restrictions such as check valves, tight bends or anything smaller than 3/8" ID. Remove or replace any restrictions found.
- Remove thermostat housing and all it's connecting hoses.
- Remove entire intake manifold, both bottom and top assembly. Note: Must unplug all injector connectors before removing and pull away from fuel rail.
- Push factory-wiring harness to backside of motor so it's out of the way.
- Remove stock sensors from intake such as intake air temp sensor (located above #7 runner on intake) and 2 coolant temp senders (gauge and ECU).
- Remove stock circulating water pump from block and all of it's connecting hoses.
- (SERP)** Remove stock adjustable idler support bracket from engine (this requires loosening of other brackets, reinstall them when done removing idler bracket).

- (VBELT)** Remove mechanical fuel pump from sea pump assembly and install supplied fuel pump block off plate with the 3/8" x 1/2" socket head allens.
 - Separate the intake manifold from the intercooler/SC assembly by removing the 8 3/8" hex bolts.
3. Install factory sensors:
- Install stock coolant temp sensors in new intake manifold by installing the single post gauge sender into portside NPT port. Install the ECM sender (yellow/black wires) to port side NPT. Use teflon pipe sealant on threads of sensors.
 - Install Inlet Air Temp sensor into 3/8" NPT located on the backside of manifold.
4. Intercooler and engine block water dump fittings: **DO NOT RESTRICT OUTLET**
- Find visible location for both dumps above the water line. Remember, if you install the stainless tee for the intercooler, it will run all the time, even when idling.
 - Mark your spots on the boat, and drill a hole using a 3/4" drill or hole saw.
 - Apply marine type silicone to exposed wood and fiberglass as well as the back of thru hull fittings.
 - While holding thru-hull fitting (do not let it rotate) on outside of boat, install the supplied aluminum 8AN nut and tighten. Do the same for both thru-hull fittings.
 - Apply thread sealant to threads of supplied 1/4" tee's male thread. Install tee fitting into thru-hull dump fitting that is tapped 1/4" NPT. Install the 2 1/4" 90 degree barbed fittings (apply thread sealant) into female ends of tee fitting.
 - Once tightened, wipe the excess silicone off and let the silicone dry.
5. **(MEFI 1)** You must upgrade to MEFI 3 or MEFI 4 ECM's. It's best to do the wiring mods before you install the supercharger. Follow the wiring diagram at the end of the instructions.
- NOTE:** It is beneficial to skip to instruction 23 at this time so you can install the injector connectors while you have the blower off the intake.
6. Intake manifold installation:
- Clean intake manifold and cylinder head surface.
 - NOTE.** Apply thick bead of RTV silicone around all 4 water passages on cylinder heads.

- ☐ ➔ **NOTE.** Mark and cut the intake gaskets to clear the galley pan mounts if required. **See figure.**

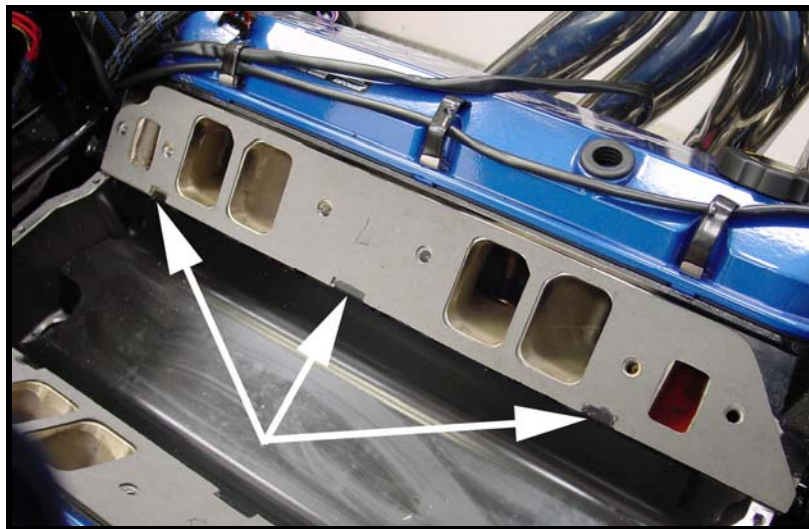

- ☐ Install new supplied intake gasket to cylinder head.
- ☐ ➔ **NOTE.** Apply a thick bead of black RTV silicone on the intake gaskets around the water passages to insure sealing around the water passages.
- ☐ ➔ **NOTE.** Apply a thick bead in the valley of the block, both front and rear. This should be a minimum of 3/8" ID tall. **See figure.**

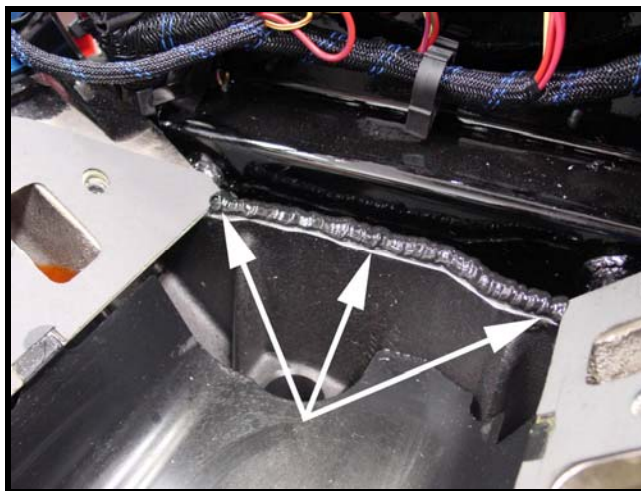

- ☐ Install intake manifold using the 8 – 3/8" x 1.50" and 4 – 3/8" x 2.25" socket head allens and the .680" stainless washers. Torque to 20 foot-pounds on your first pass, torque to 35 foot-pounds on your second pass. **Note: Install all bolts hand tight and slide intake forward as much as possible, and then stab the distributor to make sure everything lines up. If it does, proceed, if it does**

not, you may have to file one of the openings, contact Whipple first.

- Line up the distributor housing to the rotor as you marked previously. If it does not line up, remove distributor and insert a screwdriver into the hole to turn the oil pump drive shaft. Repeat this adjustment as needed until the distributor can be firmly seated and all components are in alignment.
- Install hold down clamp over distributor and bolt it securely.
- Reinstall distributor cap and secure in place.
- Install the supplied manifold to intercooler housing gasket.
- Install supercharger/intercooler assembly by lying on intake manifold with throttle cable assembly as well. **NOTE:** While installing SC/intercooler assembly, you must install the 3/8" x 1.5" hex bolt in the first throttle cable bracket/intercooler mounting area. It's too long to install afterwards.
- Install all other intercooler mounting bolts hand tight and then slide the compressor assembly forward. Now torque the (8) 3/8" intercooler-mounting bolts to 35ft. lbs.
- Install new thermostat housing with the supplied 3/8" x 3/4" socket head allen bolts and new thermostat gasket. If installing the water restrictor, install flat side into intake manifold thermostat register. Install supplied 3/8" x 3/4" socket head allen in extra 2 blank holes, use pipe sealant on threads. **NOTE:** Do not install a thermostat, this system is made to run with NO THERMOSTAT.

7. Install spark plug wires (replace if you have over 100 hours or 2 seasons on current wires). Firing order is 1-8-4-3-6-5-7-2. (Whipple recommends MSD 8.5mm plug wires)

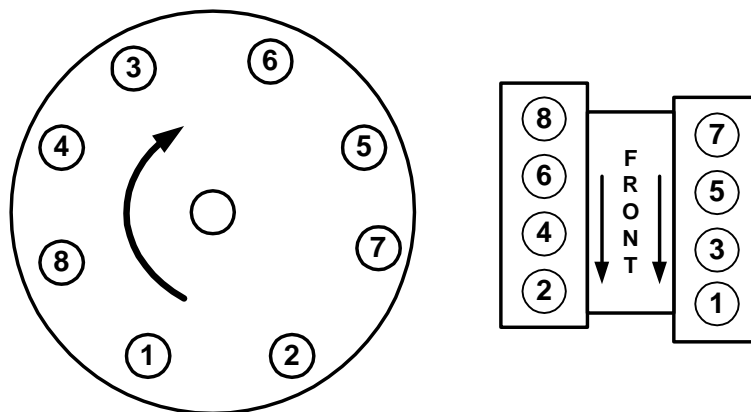

It is recommended to use a few tie straps for this step: they're cheap!!!

8. Make sure the mounting surface of the new crank pulley on the front of the balancer is perfectly flat. If necessary, remove the imperfections or paint with a good flat file.

- (SERP)** Install the Whipple dual serpentine crank pulley on the factory balancer utilizing the 3/8" x 2.5" hex head bolts. Each bolt should get 1 AN flat washer (goes against crank pulley) and lock washer. Apply a small amount of Red Loctite™ on threads to new longer crank pulley bolts and torque to 35 foot-pounds.
- (VBELT)** Install the Whipple triple V/serpentine crank pulley on to the factory balancer utilizing the 3/8" x 3.5" hex head bolts. Each bolt should get 1 AN flat washer (goes against crank pulley) and lock washer. Apply a small amount of Red Loctite™ on threads to new longer crank pulley bolts and torque to 35 foot-pounds.

9. Stainless water cross-over system:

- (VBELT)** Install stainless water cross over utilizing the new gaskets and 4 3/8" x 3/4" socket head allen bolts. Inlet feed should be facing up, starboard side.
- (SERP)** Install stainless water cross over with new gaskets (**figure 1**), this requires you to install the new billet belt system at the same time. Use the 4 aluminum spacers that fit against the water cross over and through the new plate, use the 2 - 3/8" x 3.5" socket head allens and washers to secure starboard side of plate. See **figure 2** and **following diagram**. On the port side, use the supplied oil cooler/power steering support bracket with 2 3/8" x 3.75" socket head allen bolts.

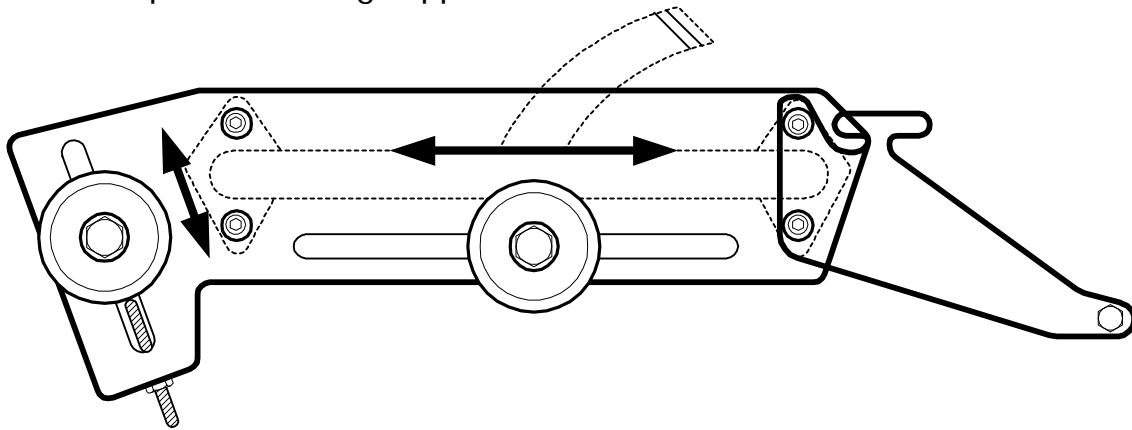

10. Front plate/support installation:

- Take the round support stands and tighten on setscrews. Tighten using the hex area on stand.
- Take front plate assembly and slide collar and front plate over the drive just slightly. **NOTE: 1/4" allens in collar are not tight, must apply blue Loctite.**
- Install the 3/8" X 1" socket head allen bolts hand tight through front plate to support stands and follow by aligning front plate with SC pulley and support stands. The drive collar must be tightened evenly, do not just tighten the button head allen

bolts, snug the collar locking bolt and the collar to plate bolts.

- Once aligned, remove blower pulley for access to drive collar bolts.
- Remove drive collar socket head allen bolts one at a time so you don't lose your alignment, apply light amount of **blue Loctite** and tighten ¼" socket head allens on collar.
- Tighten the 3/8" x 1.5" button head allen bolts into support stands to secure front plate. Torque to 22 ft. lbs.
- Install blower pulley with the supplied 6mm x 14mm socket head allen bolts. Hold drive hub from spinning by using a large metric allen in center of drive hub. Then tighten blower pulley bolts to 120 inch pounds. **NOTE: Install dry, no Loctite.**

11. There are two ways of routing your fuel system. Ideally, you want to return all fuel to an open port in the fuel tank(s). This will allow proper cooling of the fuel. You will then route the inlet from the tank to the inlet of the fuel filter, then you will return all fuel to the tank. If your boat does not have an open port for return, then you must utilize the fuel cooler and inlet tee for returning fuel.

12. Assemble fuel pressure regulator:

- Install barbed brass fitting with o-ring (be very careful, very breakable).
- Install adjusting set screw and nut, do not install tight at this time.
- Install -6 o-ring to -6 AN flare fitting into return side of regulator.
- Install supplied 1/8" pipe plug into fuel pressure regulator. Apply light amount of thread sealant to threads.
- Install the -10 oring to the -10AN to -6AN fuel fitting **(93-98 MEFI1 ONLY)**.
- Install the -10AN to -6AN fuel fitting into either side of regulator **(93-98 MEFI1 ONLY)**.
- Install the -10AN plug fitting into fuel pressure regulator (either side) **(93-98 MEFI1 ONLY)**.

13. Remote mount fuel pressure regulator with the supplied bracket and hardware. Ideally this should be within 3 feet of the fuel rail.

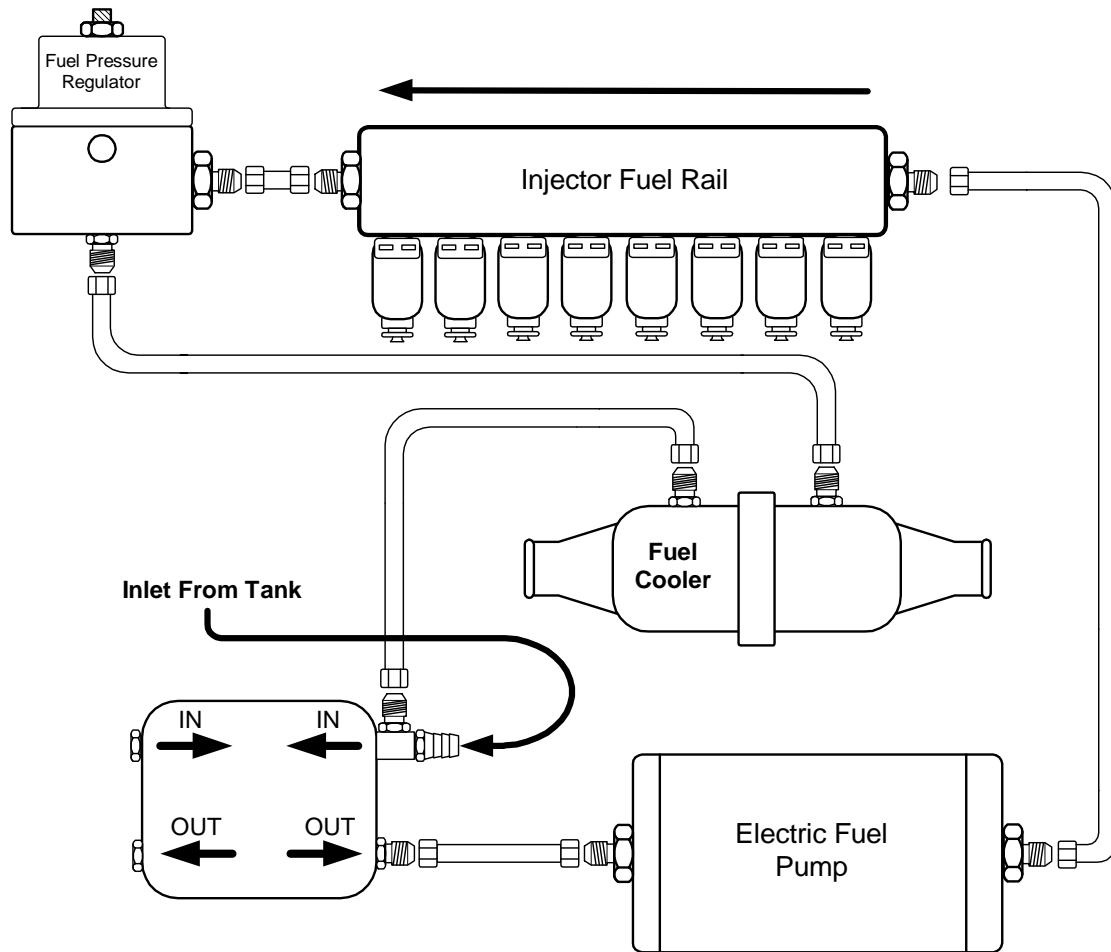

14. **(93-98 MEFI 1)** Fuel system installation: NOTE: Never use thread/pipe sealant on o-ring style fuel fitting.

- Inspect factory fuel lines from tank(s), check for any restrictions such as check valves and inline filters. All restrictions must be removed to allow proper fuel flow.
- Remove factory fuel lines and fittings from stock fuel filter.
- Install supplied 1/4" NPT brass Tee to the stock fuel filter IN. Apply light amount of pipe sealant to pipe thread.
- Install factory barbed fitting into Tee fitting. Install factory 3/8" ID fuel hose from tank and tighten clamp.
- Install (1) 1/4" NPT pipe to -6AN fuel fitting into 1/4" NPT brass tee fitting.
- Install (1) 1/4" NPT pipe to -6AN fuel fitting in the stock fuel filter OUT.
- Install supplied -10AN (3) o-rings to the -10AN to -6AN

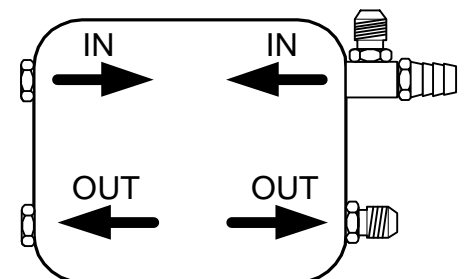

fuel fittings.

- Install the supplied (2) –10AN flow to –6AN flare fittings in the inlet and outlet ports of the new hi-flow fuel pump.
 - Install supplied (1) –10AN flow to –6AN flare fitting into inlet of fuel PSI regulator (either side will work). Install supplied –10AN plug to empty inlet port of fuel PSI regulator.
 - Pre-plan the fuel line routing so you can mount the fuel pump and fuel cooler in proper locations. It's best suited to install pump at a lower level than the fuel tank.
 - Find a secure location to mount hi-flow electric fuel pump. Note that this pumps vibrates and can cause a harmonic noise if not mounted securely.
 - Install pipe sealant to fuel cooler –6AN steel fittings. Install fittings to cooler.
 - Find a secure mounting location for the fuel cooler, mount cooler. This can be located anywhere in the factory water system after the sea pump outlet.
 - You must now manufacture fuel lines. Use only high quality, USCG approved, high-pressure fuel lines!!** You may order crimped 3/8" USCG approved fuel lines from Whipple for a minimal charge. You must supply Whipple with line length and type of fitting (90° or straight only).
 - Manufacture fuel line utilizing 3/8" ID hose from the pump OUTLET to the –6 fitting on the starboard side of the fuel rail –6 fitting.
 - Manufacture fuel line utilizing 3/8" ID hose from the port side fuel rail –6AN fitting to the –6AN fitting to the inlet of fuel PSI regulator.
 - Manufacture a fuel line utilizing 3/8" ID fuel line from the regulator return to the new supplied fuel cooler.
 - Manufacture another 3/8" ID fuel line from the fuel cooler to the –6 fitting you installed into the brass ¼" Tee fitting (IN @ fuel filter).
 - Locate the barbed fitting on starboard side of intake manifold (5/32"). Install supplied 5/32" vacuum hose and route to fuel pressure regulator barbed port. Secure with zip ties. Avoid tight bends and kinks.
15. **(99-2002 MEFI3)** Fuel system installation: NOTE: Never use thread/pipe sealant on o-ring style fuel fitting.
- Inspect factory fuel lines from tank(s), check for any restrictions such as check valves and inline filters. All restrictions must be removed to allow proper fuel flow.

- Remove factory fuel lines and fittings from stock fuel filter except for factory inlet.
- Install supplied 1/4" NPT pipe to 3/8" barbed fitting into the stock fuel filter IN #1. Apply light amount of pipe sealant to pipe thread. Face barbed fitting straight down.
- Install (1) 1/4" NPT pipe to -6AN fuel fitting in the stock fuel filter OUT #1.
- Install (1) 1/4" NPT pipe to -6AN fuel fitting in the stock fuel filter IN #2.
- Install supplied -10AN (3) o-rings to the -10AN fuel fittings.
- Install the supplied (2) -10AN flow to -6AN flare fittings in the inlet and outlet ports of the new hi-flow fuel pump.
- Install supplied (1) -10AN flow to -6AN flare fitting into inlet of fuel PSI regulator (either side will work). Install supplied -10AN plug to empty inlet port of fuel PSI regulator.
- Pre-plan the fuel line routing so you can mount the fuel pump and fuel cooler in proper locations.
- Find a secure location to mount hi-flow electric fuel pump. Note that this pumps vibrates and can cause a harmonic noise if not mounted securely.
- Install rubber strips on fuel pump clamps, mount pump in clamps using the supplied brackets, and tighten clamps. Make sure the rubber strips are on straight.
- Install pipe sealant to fuel cooler -6AN steel fittings. Install fittings to cooler.
- Find a secure mounting location for the fuel cooler, mount cooler. This can be located anywhere in the factory water system after the sea pump outlet.
- Install factory fuel line from tank to barbed fitting, secure with factory clamp (utilize factory fuel line and clamp that routed to the first stock fuel pump).
- You must now manufacture fuel lines. Use only high quality, USCG approved, high-pressure fuel lines!!** You may order crimped 3/8" USCG approved fuel lines from Whipple for a minimal charge. You must supply Whipple with line length and type of fitting (90° or straight only).
- Manufacture fuel line utilizing 3/8" ID hose from the pump OUTLET to the -6 fitting on the starboard side of the fuel rail -6 fitting.

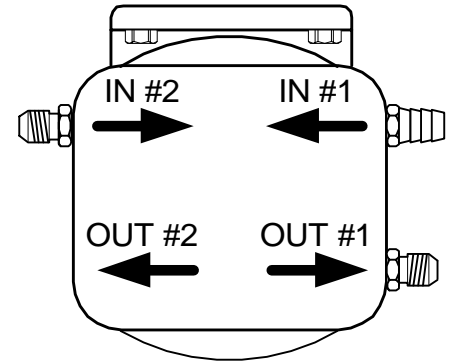

- Manufacture fuel line utilizing 3/8" ID hose from the port side fuel rail –6AN fitting to the –6AN fitting to the inlet of fuel PSI regulator.
- Manufacture a fuel line utilizing 3/8" ID fuel line from the regulator return to the new supplied fuel cooler.
- Manufacture another 3/8" ID fuel line from the fuel cooler to the –6AN fitting you installed into filter IN #2.
- Locate the barbed fitting on starboard side of intake manifold (5/32"). Install supplied 5/32" vacuum hose and route to fuel pressure regulator barbed port. Secure with zip ties. Avoid tight bends and kinks.

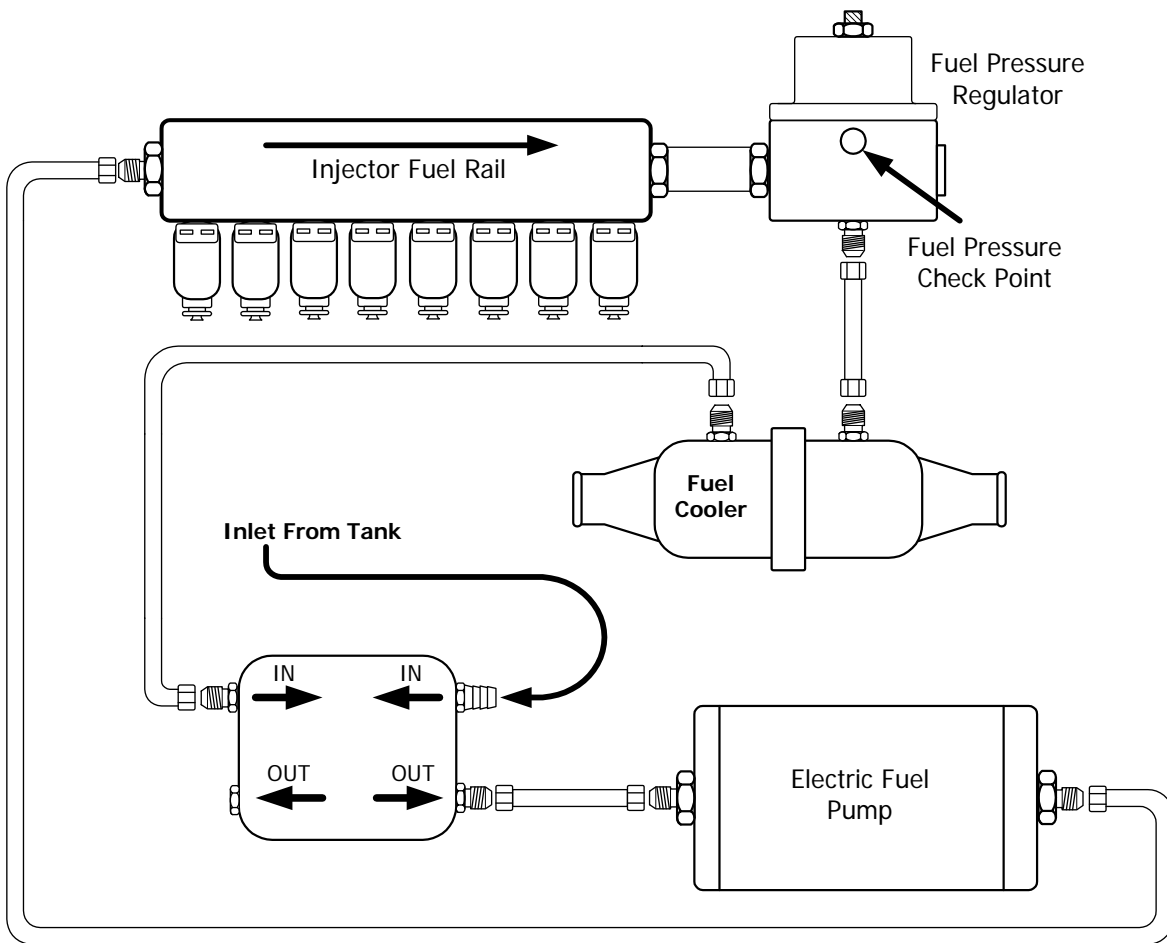

16. Water routing:

- (SERP)** Use the supplied "U Bend" hose to connect too water crossover inlet (**figure 4**) from the factory oil cooler. Cut supplied hose and fit so there are no kinks of any kind (see **following diagram** for reference). Secure hose with factory clamp off.

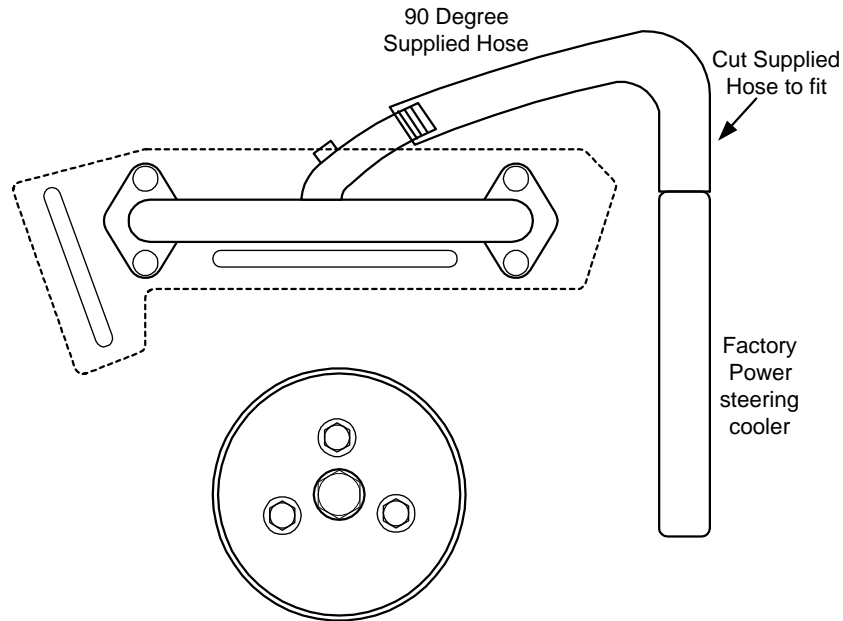

- ❑ **(SERP)** Install intercooler water supply (preferably separate pickup) from external pickup or supplied tee. The tee should be installed after the sea pump, preferably near the starter. Secure with #20 hose clamps.
- ❑ **(VBELT)** Utilize factory hose from factory coolers. Utilize the supplied U bend hose and couple to the factory hose. Use the supplied intercooler tee or hose coupler. Cut hose to fit. Some hoses may need to be replaced if worn or cracked.

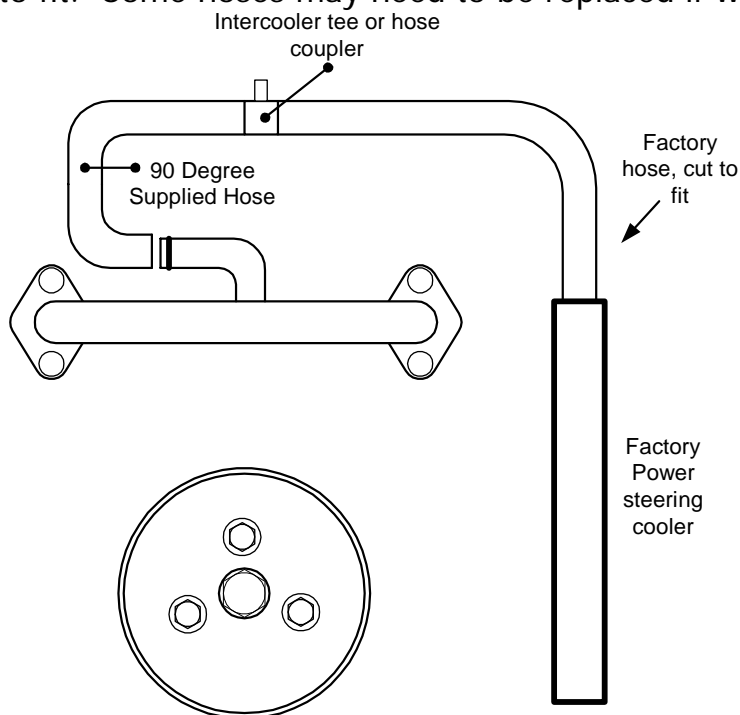

- ❑ Install supplied 5/8" ID hose from intercooler tee to the port side -10AN intercooler

inlet and secure with #10 hose clamps.

- Install 5/8" ID hose from starboard side intercooler fitting and route to fuel cooler and secure with #10 hose clamps.
- Route 5/8" ID hose from fuel cooler to intercooler dump fitting you installed earlier.
- Install brass – 8 push lock fitting to intercooler dump fitting and follow by pushing the 5/8" ID hose on push lock fitting.
- Install factory hose and clamps to new thermostat housing and bottom water feed on stainless exhaust.
- Install supplied tee with dual 1/4" fittings and male pipe into the thru-hull fittings that is threaded on the inside. Use pipe sealant on all fittings.
- Make up 1/4" ID hose from the fittings coming out of the back of the intake manifold to the water dump fitting with the tee installed. Secure with hose clamps.

17. Take factory PCV valve and take straight plastic top off. 93-97 engines will receive PCV valve to install into port side valve cover. Route 3/8" hose to barbed fitting coming from throttle body.
 - Install new 3/8" ID hose with new 90-degree plastic fitting onto PCV valve.
 - Insert PCV valve in port side valve cover. Route hose to 90 degree fitting on throttle body as shown in **figure 5**.
18. Utilize the factory 1/2" hose that was used on the breathers to install the small breather. You may mount this wherever you want, or cut real short and let it sit there (see **figure 6**). Secure both ends with #6 hose clamps.
19. Install factory 6 rib grooved idler on Whipple plate on diagonal position with adjusting setscrew up and down. Use the tee nut to slide back and forth, the idler spacer to space idler out correctly and the idler washer that centers the hex bolt on front side of idler bearing.
20. **(VBELT)** Install the 2 new supplied v-belts to accessories. You will reutilize one factory belt.
21. **(SERP)** Install new 6 rib belt as shown in this diagram: Once installed tighten by using the all thread stud on the bottom of the idler **as shown in following diagram**.

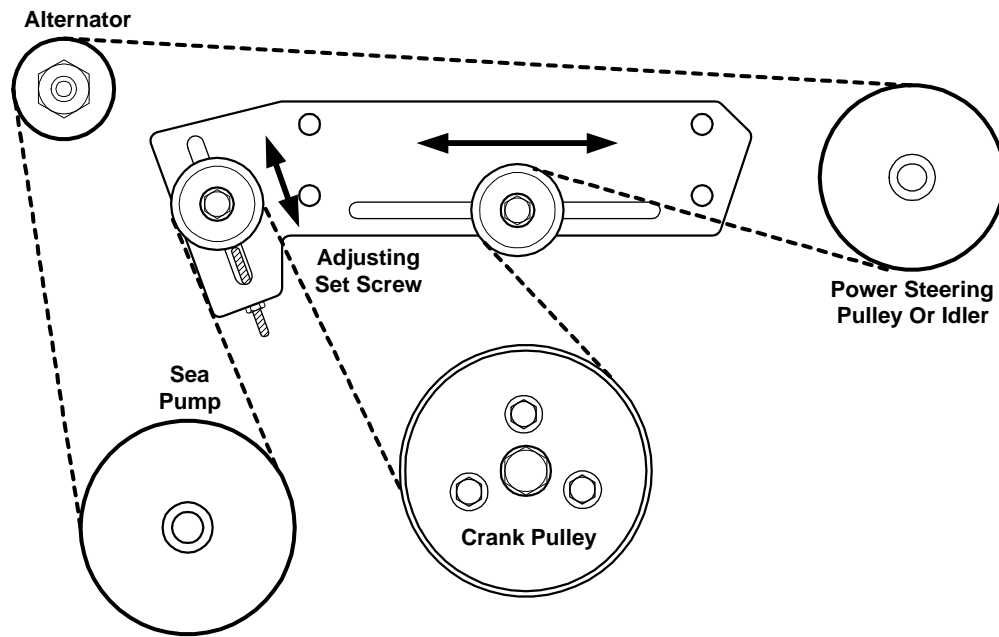

22. **(99-2002 MEFI 3)** Relocate factory "Merthacode" assembly on back side of head with the supplied steel bracket (center of plate has 2 cutouts). Use supplied 3/8" x 3/4" socket head stainless bolts and 3/8" S.S. AN washers to secure.
23. Locate the barbed fitting on starboard side of intake manifold. Install supplied 7/32" vacuum line to this and route to map sensor that is located on backside of front plate. Secure with zip ties.
24. Locate the barbed fitting on port side of intake manifold (5/32"). Install supplied 5/32" vacuum hose and route to fuel pressure regulator barbed port. Secure with zip ties.
25. Fill supercharger with oil to middle of knurled area on dipstick, 5W-50 synthetic engine oil. **DO NOT OVERFILL SUPERCHARGER OIL LEVEL. NOTE: The SC oil system takes a maximum of 5.4oz of oil).**
 - Make sure the SC is sitting square/flat.
 - Remove -3AN allen plug and fill SC with **WHIPPLE SC OIL ONLY!!**
 - Fill to the middle of the sight glass. NOTE: The W140AX compressor takes a maximum of 5.8 fl/oz.
 - Reinstall -3AN allen plug.
 - NOTE: After running the SC, the oil level will lower due to oil filling the bearings. The proper level should be between the bottom of the sight glass and the middle.
 - Change SC oil every 50 HOURS and only use **WHIPPLE SC OIL ONLY!!**

!! CAUTION !!

Severe damage to the compressor will occur if you overfill the supercharger front gear case.

WHIPPLE SC OIL LEVEL

Fill to center of oil sight glass. 5.8 fl/oz. or 155cc.
DO NOT OVERFILL, WILL VOID WARRANTY!!

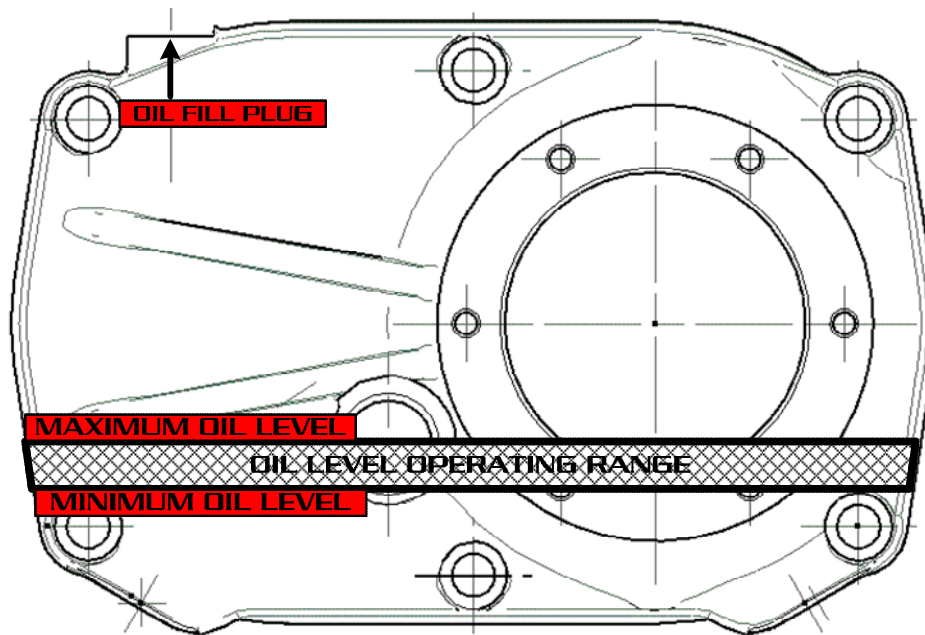

26. **WIRING INSTRUCTIONS:** MEFI1 MUST UPGRADE TO MEFI3 OR MEFI4.

- Locate all 8 injector connectors and remove protective plastic "split loom" to expose wires. At the same time, remove the TPS and IAC wires from the same loom.
- Trace the pink, blue and green wires from the injector connectors back to main portion of wiring harness. The pink wire will run into a wiring solder connection, where it's being fed by a black wire.
- Cut the blue, green and pink wires that you traced leaving approx. a few inches for a proper wiring connection.
- Utilize the supplied weather style butt connectors or solder wires to the supplied injector pigtail (allows for easy access to injector wiring). Blue to blue, green to green, black to pink. If using the butt connectors, use heat gun to shrink connector to seal wires from water. If you soldered the wires, use heat shrink tubing over wires and seal with electric tape.
- Re-loom the harness with the factory split loom and route the injector harness pigtail, TPS and IAC connectors towards the port-rear of engine.
- Plug in the IAC extension harness (one yellow end, one black end) to factory IAC connector and route to starboard/rear of engine.

- Some may need to separate the supercharger from the intercooler housing by removing the 3 3/8" hex bolts to get to the injector connectors. If you separate them, clean the silicone from the 2 surfaces and reseal with black RTV silicone when putting back together. Torque to 35 ft. lbs.
- Plug in factory TPS connector to new TPS sensor.
- Plug in factory IAC connector to IAC motor on starboard side.
- Install factory connector to Inlet Air Temp sensor.
- Connect brown engine coolant temp sensor wire for gauge.
- Connect factory engine coolant temp sensor to sensor in manifold.
- Find the factory map sensor connector and plug in the wiring extension. Now install the new orange map sensor connector to the map sensor located on the front plate. See **figure 7**.
- Locate the factory electric fuel pump connector. This connector has a gray wire (Pin A), which is the turn on wire and a black wire (Pin B), which is a ground.
- Cut the factory connector off, strip wires and connect to supplied relay harness (**see following diagram** for reference). Connect the new harness gray wire to factory gray wire. Connect new harness black wire to factory black wire (preferable solder and heat shrink). Mount relay and fuse on back of engine or transom.
- Route red wire from fuse junction to battery power.
- Route orange wire to electric fuel pump positive +. **(10 or 12 ga only!!!)**

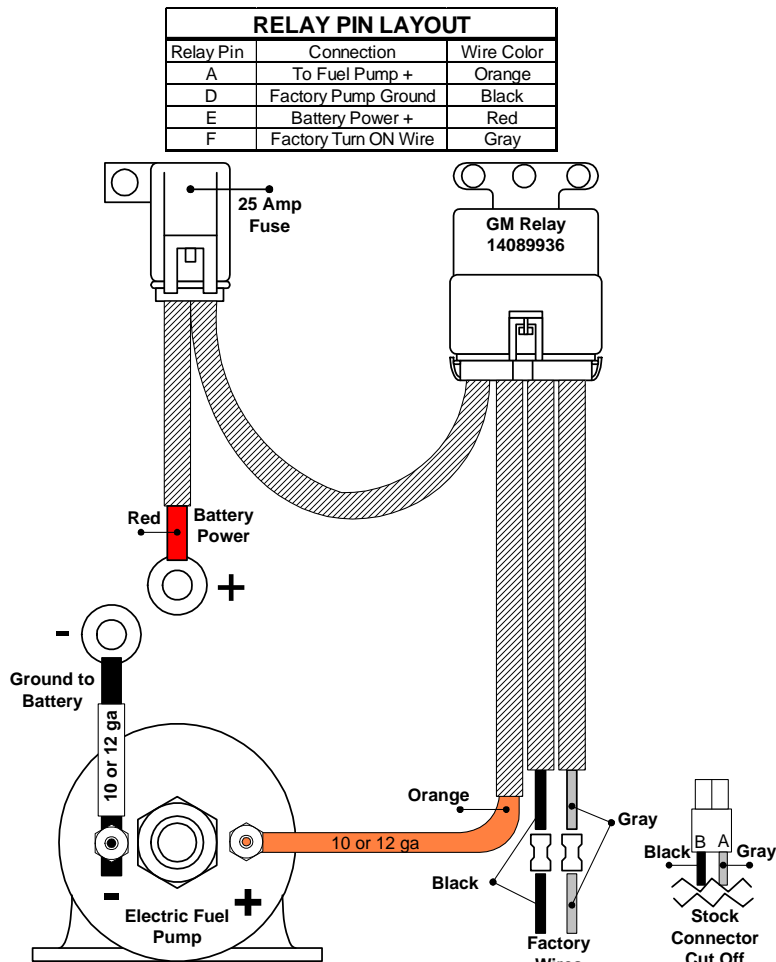

27. Install SC belt by releasing the tension from the tensioner and loosening the mounting bolt on the sliding idler.



Once belt is on all pulleys, push the sliding idler towards starboard side until you can release the tensioner so that it's pointing at a 5 O'clock position. Notice the stops on the tensioner, it must have play both forward and backwards to work properly. **See following diagram.**

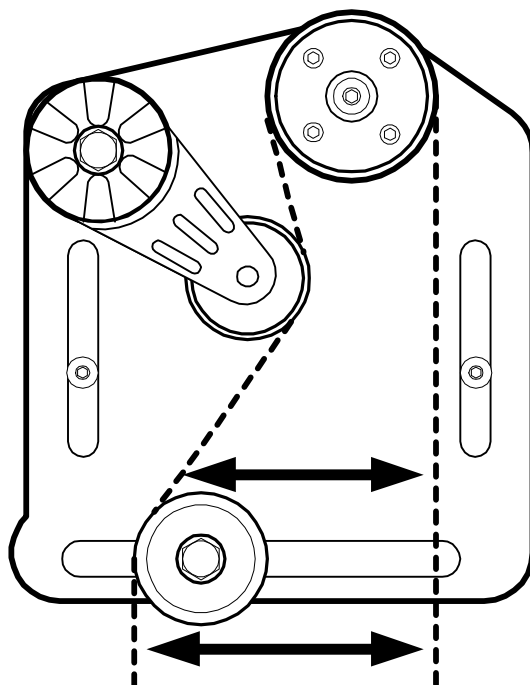

28. Throttle linkage installation: (See figure 8)

- Install factory throttle linkage anchor bolt into "L" adapter.
- Install factory throttle linkage bolt in throttle arm.
- Adjust linkage so that the linkage barely fits on the linkage bolt, so that the linkage is always being forced to it's maximum closing position.
- Adjust heim joints as needed.
- Tighten all bolts, allens, etc. on throttle assembly.
- Verify that the linkage does not go over center at any time. Should be able to go back and forth 100% without binding.

BEFORE STARTING THE ENGINE

MAKE SURE THE THROTTLE CABLE OPERATION IS CORRECT. WITH THE ENGINE OFF, MOVE THE THROTTLE A FEW TIMES TO FULL OPEN AND CLOSED POSITIONS. THERE SHOULD BE NO BINDING OR STICKING AND SHOULD OPERATE FREELY.

PRIME FUEL PUMP WITH FUEL!! DO NOT RUN THIS PUMP DRY UNDER ANY CIRCUMSTANCES!! THERE ARE NO WARRANTIES FOR PUMPS RAN DRY.

29. Adjust fuel pressure TEMPORARILY: **DO NOT RUN PUMP DRY!!!!**

- Install quality mechanical fuel pressure gauge (do not use electric gauges to tune)

to 1/8" pipe fitting on adjustable regulator.

- Prime fuel system so that filter is full of 91-octane gas.
- Turn key "on" and quickly bleed air from fuel line anywhere on pressure side.
- Turn key to on position, look at pressure and adjust close to **40lbs**. **This is temporary to get the engine running.**

30. You must set base ignition timing at 8 degrees.

- Connect timing light to number 1 ignition wire.
- Start the engine and let idle (may have to give some slight throttle).
- Connect the appropriate tool (timing tool #91-805747A1), Rinda scan tool or jump pins A & B on the DLC with a bare wire/paper clip to hold the engine in base timing mode.
- Manually adjust throttle so engine RPM is steady 1500rpm.
- If you have a Rinda scan tool, set the engine in "service mode" which will set it in base timing mode.
- Shine the timing light at the timing mark indicator located on the timing chain cover.
- Adjust the distributor until you get the desired 8 degrees BTDC. Clockwise to retard timing, counter-clockwise to advance timing.
- Torque distributor bolt down bolt to 30 foot-pounds.
- Verify that the motor is 8 degrees BTDC after the distributor was tighten, adjust if needed.
- Set scan tool to "normal mode" or remove the base timing tool.

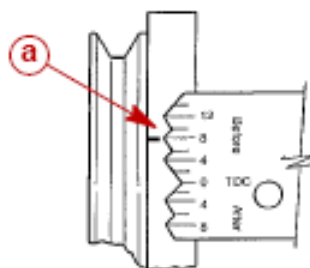

a - Timing Marks

YOU MUST USE A HIGH QUALITY, HIGH ACCURACY MECHANICAL FUEL PRESSURE GAUGE ONLY!!! NEVER ADJUST WITH AN ELECTRIC GAUGE!!

- With **NO** vacuum reference, adjust fuel pressure regulator by turning top allen

screw on regulator (clockwise for more pressure, counter clockwise for less) until you reach 40 lbs. of fuel pressure. Tighten nut on regulator so allen does not vibrate out.

- Install 5/32" vacuum/boost line onto regulator barbed fitting. Secure lines with zip ties. With motor running in vacuum, pressure should drop once line is connected and will rise above 40 under boost. Under full boost, the fuel pressure must hold a steady 45lbs. of pressure (+/- 2lbs). If not, there is a restriction in the line.

IDLE SPEED SETTING

31. Some motors may need an idle adjustment. First, you must understand the ECU has a desired idle speed that the motor is always going to try to achieve. The rpm idle speed should be 750 rpm once motor is up in the 80+ range of engine coolant temperature.

- On the starboard side of throttle body, there's the linkage arm that is pushed over a splined shaft. Remove the linkage arm from the throttle body so you can have better access to the throttle stops.
- You must adjust the setscrew to raise or lower the idle speed. Note that this is where the throttle stops in the relaxed or returned position.

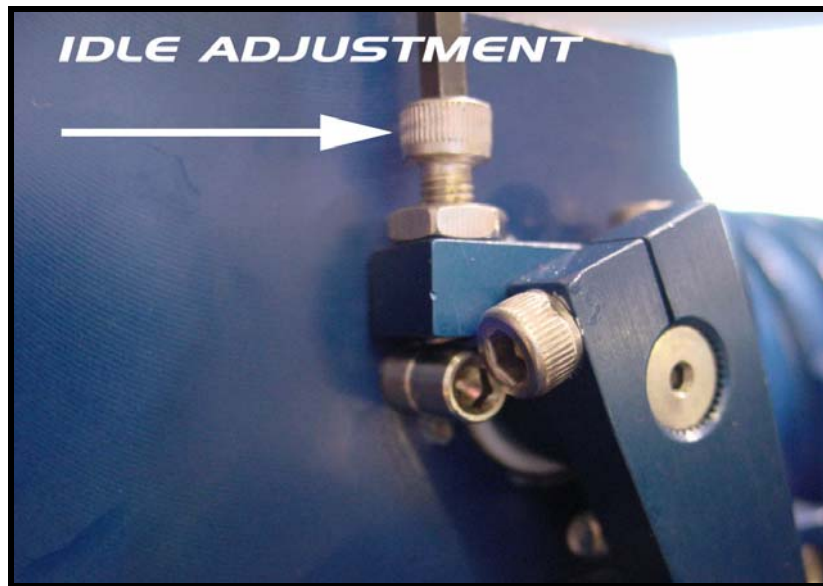

Engines that idle to high:

- This means either there's a vacuum leak, too much timing or there is too much air going by the throttle blades. To lower airflow at idle, take the set screw/throttle stop and lower it. This allows the throttle blade to close more when returned. Make small adjustments such as 1/8th turns. **NOTE: Don't forget to tighten locking**

nut after adjustment.

Engines that idle to low:

- This means either there's not enough air being fed to engine or not enough timing. To increase airflow at idle, take the set screw/throttle stop and raise it so when the throttle is in its relaxed position, it will be slightly open more. Make small adjustments such as 1/8th turns. **NOTE: Don't forget to tighten locking nut after adjustment.**
- To raise the voltage, you must make the setscrew (acts as throttle stop when in returned position) open the throttle blade more. This will raise the RPM (if it's loping between 600-1000, open the blade). If the RPM is too high, you must close the blade (lower the voltage). If you do have a scanner, watch the IAC count. You want it to be between 20-50. You must shut the motor off for 5 seconds to reset the IAC motor. If you do not have a scanner, you can adjust this setscrew until you see the motor idles around 750 on the tachometer, the motor should not hunt more than 100 RPM.
- Rev engine up past 2500 rpm and bring back at a rapid rate. The motor should not die, it should come back to the desired idle speed within 1-5 seconds. If it dies, then it needs more air so follow instructions for engines that idle too low.

Motors that idle high only after revving the engine or there are no more adjustments to be made:

- This means the TPS voltage is slightly off and that it does not return to its "Closed Loop Idle System." To fix this, you must loosen the TPS sensor (located on port side of throttle body) and push the top out towards the back of the boat. This will lower the TPS voltage. Tighten allens and try starting it again. You may want to use the scanner or a volt-meter (0-5volt sensor output) to watch the voltage come down. Ideal voltage should be in the range of 0.45 – 0.55 volts.

CRITICAL!!!

LAKE TEST POST-INSTALLATION CHECKLIST

After installing the Whipple supercharger kit it is imperative that the following checklist be performed. Failure to perform these simple tests may result in severe engine damage.

1. Make sure 91 octane or higher is in the vessel. If unsure, then drain the tank completely

empty and fill with 91 or higher.

2. With the thermostat removed, under full throttle operation, near full speed, block pressure should be a minimum of 25lbs. and maximum of 40lbs. If block pressure is not present, severe engine damage may occur. The motor should have 0-2lbs. at idle and should progressively get higher as speeds increase. A low water nose style pickup or external pickup may need to be installed. The Mercury side hole pickups will not generate enough water flow for proper operation. If you have an XZ drive with dual water pickups, it **WILL** be necessary to plug side draft holes to increase pressure.
3. Fuel pressure is the most critical parameter and must be checked during wide-open throttle operation. Install a quality fuel pressure gauge to the extra port at the auxiliary fuel rail added by Whipple (1/8" pipe). Attach the fuel pressure gauge with a long enough hose so that it may be visible during operation. Under WOT, full boost, max rpm, the fuel pressure should be 45 lbs (+/- 2lbs). This procedure takes two people – one to drive and the other to observe the gauge. Perform the test in a safe area. If it does not maintain fuel pressure, you must find the restriction, as this results in a lean air to fuel condition.

MAINTENANCE AND SERVICE

It is recommended that the following items be checked at normal service intervals.

1. Check supercharger oil every 10-15 hours of operation.
2. Clean idle air motor filter every 10-15 hours.
3. Remove and clean flame arrestor elements every 10-15 hours.
4. Change supercharger oil every 50 hours or every season, which ever comes first.
5. Check the supercharger/accessory drive belt. Adjust or replace as required.
6. Inspect and replace fuel filter every 50 hours.
7. Replace factory spark plugs every 50 hours.
8. Back flush intercooler every 50 hours or once a season.
9. Follow your standard Mercury Marine service intervals.

DO NOT!!!

1. Never run octane less than 91.
2. Do not use octane booster, these are very hard on the spark plugs and only increase a few points. Example: 87 octane with octane booster, may raise a few "points" to 87.5, which is not acceptable.
3. Never operate engine if overheating.
4. Never operate engine in boost if water temp exceeds 140.
5. Do not operate engine in boost if water pressure has fallen below standard levels.
6. Do not operate engine in boost if fuel pressure falls below standard levels.

7. Do not tee the vacuum/boost line feeding the Map sensor, use the other pipe holes located in the manifold.
8. Do not design your own fuel system, the system is designed for use and installation as we specify.
9. Do not run more timing than 8 degrees base.
10. Never run a hotter spark plug, only run factory replacements or one heat range colder. Gap plugs to .032".

MEFI 1 & 2				MEFI 3			
Pin Location	Signal/Sensor	Color Wire	>>>>	Pin Location	Signal/Sensor	Color Wire	Extra Information
J1-1	Knock sensor signal	Black	>>>	J1-30	Knock Sensor Signal	Dark Blue	Knock sensor
J1-2	Coolant sensor signal	Yellow	>>>	J2-11	Coolant sensor signal	Yellow	ECT sensor connector pin B
J1-3	Not used						
J1-4	I/O Fluid level	Dark Green					
J1-5	Master/Slave	Yellow	>>>	J2-21	Master/Slave	Yellow	Engine 2
J1-6	Oil pressure	Brown	>>>	J2-7	Oil Pressure	Blue	Oil pressure switch
J1-7	Diagnostic Test	White/Black	>>>	J2-22	Diagnostic Test	Black/White	Diagnostic B
J1-8	Not used						
J1-9	MAP signal	Light Green	>>>	J2-27	Map Signal	Light Green	Map sensor connector pin B
J1-10	TPS Signal	Dark Blue	>>>	J2-26	TPS Signal	Dark Blue	TPS sensor connector pin C
J1-11	Ignition volts	Pink/Black	>>>	J2-32	Ignition	Pink	Relay 1 splice #30 to #86
J1-12	Not used						
J1-13	TP & IAT Ground	Black	>>>	J2-3	TP & IAT ground	Black	TPS connector pin B, IAT connector pin B
J1-14	ECM Ground	Black/White	>>>	J1-20	ECM ground	Black	Ground
J1-15	TPS 5V reference	Gray	>>>	J2-4	TPS 5V reference	Gray	TPS sensor connector pin A
J1-16	Battery	Orange	>>>	J2-1	Battery	Orange	Diagnostic F (Battery)
J1-17	Not used						
J1-18	Serial data	Orange/Black	>>>	J1-32	Serial Data	Orange	Diagnostic G (engine 2 orange)
J1-19	Not used						
J1-20	Oil level	Light Blue	>>>	J2-23	Oil level		
J1-21	Emergency stop	Pink	>>>	J2-5	Emergency stop		
J1-22	Not used						
J1-23	Not used						
J1-24	Inlet air temp signal	Tan	>>>	J2-30	Inlet air temp signal	Tan	IAT sensor connector pin A
J1-25	Not used						
J1-26	Not used						
J1-27	Not used						
J1-28	Not used						
J1-29	MAP & coolant ground	Black	>>>	J2-18	MAP & coolant ground	Black	ECT connector pin B, MAP connector pin A
J1-30	ECM Ground	Black/White	>>>	J1-5	ECM ground	Black	Ground
J1-31	Map 5V reference	Gray	>>>	J2-19	Map 5V reference	Gray	MAP connector pin B
J1-32	Battery	Orange			Not used		

Whipple Charger Installations Instructions for Mercury 454/502 Magnum Engines

MEFI 1 & 2

Pin Location	Signal/Sensor	Color Wire	>>>>	Pin Location	Signal/Sensor	Color Wire	Extra information
J2-1	Not used						
J2-2	Not used						
J2-3	Not used						
J2-4	Not used						
J2-5	Injector driver B Distributor control	Light Green Black/Red	>>>>	J1-17 J1-3	Injector driver B Distributor control ref low	Dark Green Red/black	Injectors 1, 4, 6, 7 all pin B Distributor 4 way connector pin A
J2-6	Injector Mode NA	White			Not used		
J2-7	MEFI3 Distributor control	Purple/White	>>>>	J2-10	Distributor control ref High	Purple/White	Distributor 4 way connector pin C
J2-8	Fuel pump relay driver	Dark Green/White	>>>>	J1-23	Fuel pump relay driver	Dark green/white	Relay 2 #85
J2-9	Not used				Not used		
J2-10	Coolant over temp Audio warning horn	Dark Green		J1-26	Audio warning horn		
J2-11	IAC "A" low	Blue/Black	>>>>	J1-12	IAC "A" low	Blue/black	IAC connector pin C
J2-13	IAC "B" high	Green/White	>>>>	J1-11	IAC "B" high	Green/white	IAC connector pin B
J2-14	ECM ground	Black/White	>>>>	J1-4	ECM ground	Black	Ground
J2-15	Not used						
J2-16	Not used						
J2-17	Not used						
J2-18	Not used						
J2-19	Not used						
J2-20	ECM ground	Black/White			Not used		
J2-21	Injector driver A MEFI3	Dark Blue White	>>>>	J1-1	Injector driver A	Dark Blue	Injectors 2, 3, 5, 8 all pin B
J2-22	Ignition control signal	White	>>>>	J1-10	Ignition control signal	White	Distributor 4 way connector pin D
J2-23	Ignition control by-pass	Tan/Black	>>>>	J1-24	Ignition control by-pass	Tan/black	Distributor 4 way connector pin B
J2-24	Not used						
J2-25	Not used						
J2-26	Oil Pressure lite	Tan	>>>>	J2-29	Oil Pressure lite		
J2-27	IAC "A" high	Blue/White	>>>>	J1-28	IAC "A" high	Blue/white	IAC connector pin D
J2-28	IAC "B" low	Green/Black	>>>>	J1-27	IAC "B" low	Green/black	IAC connector pin A
J2-29	Oil level lite	Brown/White	>>>>	J1-9	MIL lamp	Brown/white	Malfunction indicator lamp
J2-30	Not used						
J2-31	Not used						
J2-32	Not used						

MEFI 3

Relay #1	Relay #2
85 J1-23	85 Ground
86 J2-32*	86 Purple - ignition Coil gray - J2-32
87 Fuel pump gray	87 Pink
30 J2-32	30 Red battery feed

NOTE: * Cut the black/white wire from terminal 86 in fuel pump relay.

Splice the black/white wire from the relay into pink wire that is located in terminal 30. Leave the black/white wire from computer unattached install heat shrink over the end of wire.

NOTE: ** Remove the 5-way connector from the knock sensor module, cut or remove the dark blue wire from cavity E and black wire from cavity C. Splice the blue wire from cavity E to the black wire from cavity C, install heat shrink to seal the splice of wires.

Whipple Charger Installations Instructions for Mercury 454/502 Magnum Engines

MEFI 1 & 2

MEFI 4 AND 4A

Pin Location	Signal/Sensor	Color/Wire	>>>>	Pin Location	Signal/Sensor	Color/Wire	Extra information
J1-1	Knock sensor signal	Black	>>>	J1-17	Knock Sensor Signal	Dark Blue	Knock sensor
J1-2	Coolant sensor signal	Yellow	>>>	J2-7	Coolant sensor signal	Yellow	ECT sensor connector pin B
J1-3	Not used						
J1-4	I/O Fluid level	Dark Green					
J1-5	Master/Slave	Yellow	>>>	J1-3	Master/Slave	Yellow	Engine 2
J1-6	Oil pressure	Brown	>>>	J2-20	Oil Pressure	Brown	Oil pressure switch
J1-7	Diagnostic Test	White/Black	>>>	J1-2	Diagnostic Test	Black/White	Diagnostic B
J1-8	Not used						
J1-9	MAP signal	Light Green	>>>	J2-8	Map Signal	Light Green	Map sensor connector pin B
J1-10	TPS Signal	Dark Blue	>>>	J2-23	TPS Signal	Dark Blue	TPS sensor connector pin C
J1-11	Ignition feed	Pink/Black	>>>	J2-19	Ignition feed	Pink	Relay 1 splice #30 to #86
J1-12	Not used						
J1-13	TP & IAT Ground	Black	>>>	J2-3*	MAP, ECT, IAT, TPS GRD	Black	TPS connector pin B, IAT connector pin B
J1-14	ECM Ground	Black/White	>>>	J1-28**	ECM ground	Black/White	Ground
J1-15	TPS 5V reference	Gray	>>>	J2-2****	TPS 5V reference	Gray	TPS sensor connector pin A
J1-16	Battery	Orange	>>>	J2-1****	Battery	Orange	Diagnostic F (Battery)
J1-17	Not used						
J1-18	Serial data	Orange/Black	>>>	J2-10	Serial Data	Orange	Diagnostic G
J1-19	Not used						
J1-20	Oil level	Light Blue	>>>	J1-18	Oil level		
J1-21	Emergency stop	Pink	>>>	J1-5	Emergency stop		
J1-22	Not used						
J1-23	Not used						
J1-24	Inlet air temp signal	Tan	>>>	J2-21	Inlet air temp signal	Tan	IAT sensor connector pin A
J1-25	Not used						
J1-26	Not used						
J1-27	Not used						
J1-28	Not used						
J1-29	MAP & coolant ground	Black	>>>	J2-3*	MAP, ECT, IAT, TPS GRD	Black	ECT connector pin B, MAP connector pin A
J1-30	ECM Ground	Black/White	>>>	J1-28**	ECM ground	Black/White	Ground
J1-31	Map 5V reference	Gray	>>>	J2-2****	Map 5V reference	Gray	MAP connector pin B
J1-32	Battery	Orange	>>>	J2-1****	Battery	Orange	Battery

* MUST SPLICE SENSOR GROUNDS TOGETHER

** MUST SPLICE ECM GROUNDS TOGETHER

*** MUST SPLICE TPS AND MAP 5V REFERENCE TOGETHER

**** MUST SPLICE BATTERY FEED TOGETHER

Whipple Charger Installations Instructions for Mercury 454/502 Magnum Engines

MEFI1 & 2

MEFI4 and MEFI4A

Pin Location	Signal/Sensor	Color Wire	>>>>	Pin Location	Signal/Sensor	Color Wire	Extra information
J2-1	Not used						
J2-2	Not used						
J2-3	Not used						
J2-4	Not used						
J2-5	Injector driver B	Light Green	>>>	J1-11	Injector driver B	Dark Green	Injectors 1, 4, 6, 7 all pin B
J2-6	Distributor control ref low	Black/Red	>>>	J1-13	Distributor control ref low	Red/black	Distributor 4 way connector pin A
J2-7	Injector Mode NA	White			Not used		
J2-8	Distributor control ref High	Purple/White	>>>	J2-16	Distributor control ref High	Purple/White	Distributor 4 way connector pin C
J2-9	Fuel pump relay driver	Dark Green/White	>>>	J1-6	Fuel pump relay driver	Dark green/white	Relay 2 #85
J2-10	Not used				Not used		
J2-11	Coolant over temp	Dark Green			Not used		
J2-12	Audio warning horn		>>>	J1-8	Audio warning horn		
J2-13	IAC "A" low	Blue/Black	>>>	J1-31	IAC "A" low	Blue/black	IAC connector pin C
J2-14	IAC "B" high	Green/White	>>>	J1-30	IAC "B" high	Green/white	IAC connector pin B
J2-15	ECM ground	Black/White	>>>	J1-29**	ECM ground	Black	Ground
J2-16	Not used						
J2-17	Not used						
J2-18	Not used						
J2-19	Not used						
J2-20	ECM ground	Black/White	>>>	J1-29**	ECM ground	Black/White	Injectors 2, 3, 5, 8 all pin B
J2-21	Injector driver A	Dark Blue		J1-26	Injector driver A	Dark Blue	
J2-22	Injector Mode NA	White			Not used		
J2-23	Ignition control signal	White	>>>	J2-31	Ignition control signal	White	Distributor 4 way connector pin D
J2-24	Ignition control by-pass	Tan/Black	>>>	J2-15	Ignition control by-pass	Tan/Black	Distributor 4 way connector pin B
J2-25	Not used						
J2-26	Not used						
J2-27	Oil Pressure lite	Tan	>>>	N/A	Oil Pressure lite		
J2-28	IAC "A" high	Blue/White	>>>	J1-16	IAC "A" high	Blue/white	IAC connector pin D
J2-29	IAC "B" low	Green/Black	>>>	J1-15	IAC "B" low	Green/black	IAC connector pin A
J2-30	Oil level lite		>>>	J1-24	Oil level lite		
J2-31	MIL lamp	Brown/White	>>>	J1-9	MIL lamp	Brown/white	Malfunction indicator lamp
J2-32	Not used						

**** MUST SPLICE ECM GROUNDS TOGETHER**

Relay #1	Fuel Pump Relay	Color Wire	Relay #2	Ignition/System Relay
85	J1-6	Green/White	85	Ground
86	J2-19*	Black/White	86	Ignition/Red
87	Fuel pump	Gray	87	Coil gray - J2-19
30	J2-19*	Red	30	12V B+

NOTE: * Cut the black/white wire from terminal 86 in fuel pump relay.

Splice the black/white wire from the relay into red wire that is located in terminal 30.

Leave the black/white wires from ground unattached install heat shrink over the end of wire.

NOTE: **Remove the 5-way connector from the knock sensor module, cut or remove the dark blue wire from cavity E and black wire from cavity C. Splice the blue wire from cavity E to the black wire from cavity C, install heat shrink to seal the splice of wires.

MEFI4 DIAGNOSTIC INFORMATION ONLY**MEFI4 PIN CONFIGURATION
J1 CONNECTOR**

J1 Pin	Description	Color	Connector pin	Connector Type
J1-1	Knock signal #2 (N/A)	Light Green	(N/A)	(N/A)
J1-2	Diagnostic "test" terminal	Black/White	Pin B	10 Way/DLC
J1-3	Master/Slave (N/A)	Yellow	Pin B	2 Way
J1-4	Empty			
J1-5	Emergency Stop (N/A)	Pink	(N/A)	(N/A)
J1-6	Fuel pump relay control	Dark Green/White	Relay Pin 85	Fuel pump relay
J1-7	Empty			
J1-8	Audio warning horn	Dark Green/Black		
J1-9	Empty			
J1-10	Empty			
J1-11	Fuel injector driver B	Blue	Injectors Pin B	Injector connector
J1-12	Empty			
J1-13	Distributor Reference "low"	Red/Black	Pin A	4 Way/Distributor
J1-14	Tachometer output	Gray		Engine harness gray
J1-15	Idle air control B "low"	Green/Black	Pin A	4 Way/IAC
J1-16	Idle air control A "high"	Blue/White	Pin D	4 Way/IAC
J1-17	Knock signal #1	Blue	Knock Sensor	Single way
J1-18	Oil level			
J1-19	Empty			
J1-20	Shift interrupt (N/A)	White	Shift sensor	
J1-21	Empty			
J1-22	Empty			
J1-23	Empty			
J1-24	Gear lube switch	Tan/Black		
J1-25	Empty			
J1-26	Fuel injector driver A	Green	Injectors Pin B	Injector connector
J1-27	Malfunction indicator lamp	Brown/White	Pin E	10 Way/DLC
J1-28	ECM ground	Black	Engine block	Eyelet
J1-29	ECM ground	Black	Engine block	Eyelet
J1-30	Idle air control B "high"	Light Green/White	Pin B	4 Way/IAC
J1-31	Idle air control A "low"	Light Blue/Black	Pin C	4 Way/IAC
J1-32	Empty			

SYSTEM/IGNITION RELAY

Pin	Description	Color	Connector Pin
30	12V Power/B+	Red	
85	Ground	Black	
86	To ignition	Pink	
87	Ignition/Injector Fused	Red	J2-19

FUEL PUMP RELAY

Pin	Description	Color	Connector Pin
30	12V Power/B+	Red	Relay #86
85	Trigger from ECM	Dark Green/Black	J1-6
86	Inj./ECM 10A fuse	Black	J2-19
87	Fuel pump trigger ON	Gray Pin A	Pin A
87A	N/A	N/A	

**MEFI4 PIN CONFIGURATION
J2 CONNECTOR**

J2 Pin	Description	Color	Connector pin	Connector Type
J2-1	Battery feed	Orange		
J2-2	5 Volt reference	Gray	TPS-A/MAP-C	3 Way
J2-3	Sensor ground	Black	TPS-B/MAP-A	(2) 2 Way/(3) 3 Way
J2-4	Fuel PSI signal		ECT-A/IAT-B	
J2-5	Emergency Stop			
J2-6	Empty			
J2-7	ECT coolant sensor signal	Yellow	Pin B	3 Way/Coolant
J2-8	MAP sensor signal	Light Green	Pin B	3 Way
J2-9	Empty			
J2-10	Serial data	Orange	Pin G	10 Way/DLC
J2-11	Empty			
J2-12	Empty			
J2-13	Empty			
J2-14	Empty			
J2-15	Ignition bypass	Tan/Black	Pin B	4 Way/Distributor
J2-16	Distributor Reference "high"	Purple/White	Pin C	4 Way/Distributor
J2-17	Empty			
J2-18	Empty			
J2-19	Ignition feed	Pink	#30,#86	Ignition/Inj Relay
J2-20	Oil PSI switch	Blue/White		
J2-21	IAT sensor signal	Tan	Pin A	2 Way
J2-22	Empty			
J2-23	TPS sensor signal	Blue	Pin C	3 Way
J2-24	Empty			
J2-25	Empty			
J2-26	Empty			
J2-27	Empty			
J2-28	Empty			
J2-29	Empty			
J2-30	Empty			
J2-31	Ignition control	White	Pin D	4 Way
J2-32	Empty			

Whipple Charger Installations Instructions for Mercury 454/502 Magnum Engines

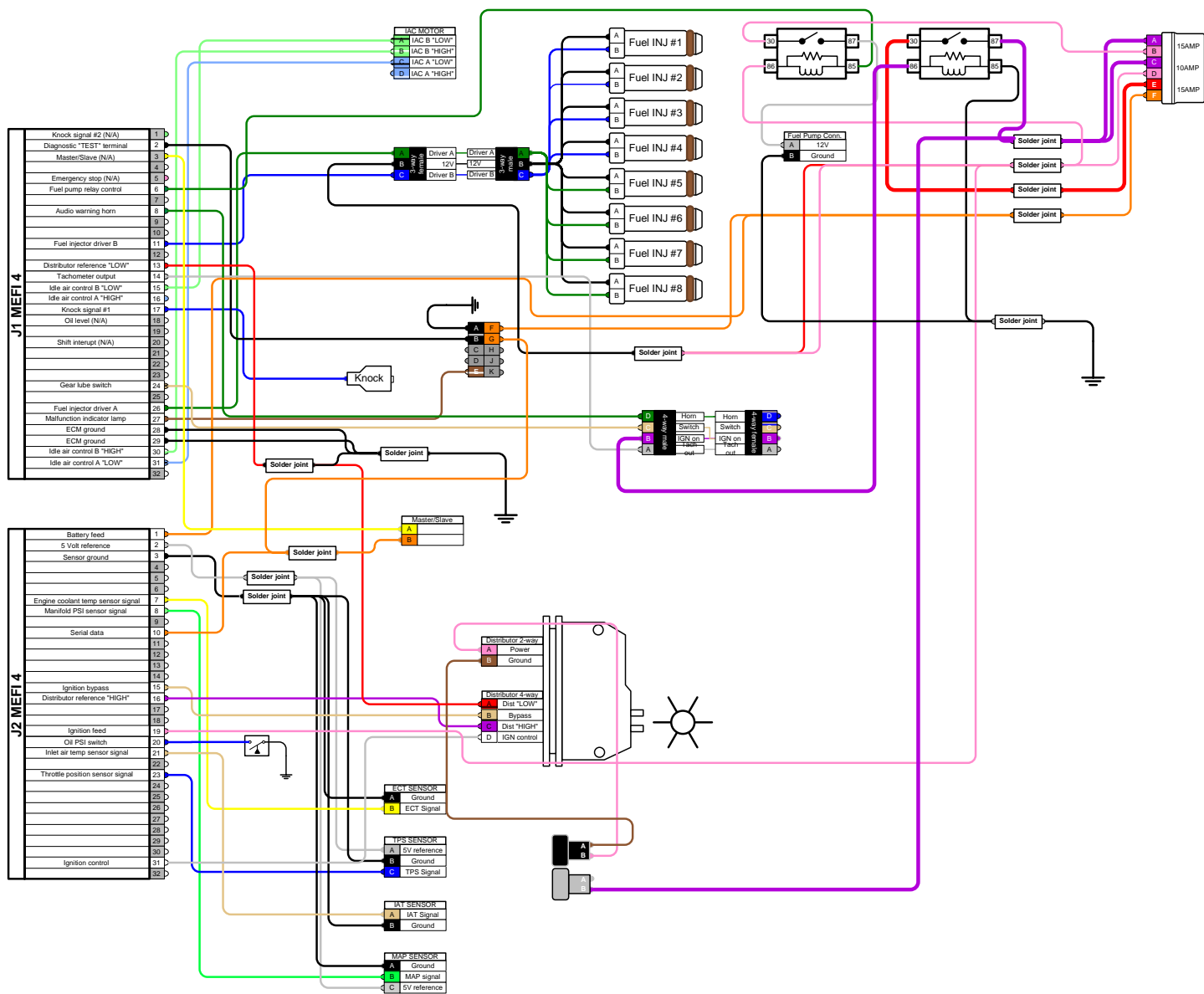

Engine Scan Tool List

The Engine Scan Tool Data List contains all engine related parameters that are available on the scan tool. Use the Engine Scan Tool Data List only after the following is determined:

- On-Board Diagnostic System Check is completed.
- No Diagnostic Trouble Codes (DTCs).
- On-board diagnostics are functioning properly.

Scan tool values from a properly running engine may be used for comparison with the engine you are diagnosing. The Engine Scan Tool Data List represents values that would be seen on a normal running engine.

Important: A scan tool that displays faulty data should not be used. The scan tool problem should be reported to the manufacturer. Use of a faulty scan tool can result in misdiagnosis and unnecessary parts replacement.

Only the parameters listed below are referenced in this service manual for use in diagnosis. If all values are within the typical range described below, refer to *Symptoms* for diagnosis.

Scan Tool Parameter	Units	Parameter Range
Calibration ID	Numeric	0-255 Identification number assigned specific calibration
Calibration Checksum	Numeric	0-65535
Engine Speed	RPM	0-6000
Desired Idle	RPM	0-1600
ECT	C, F	-40 C - 151 C, -40 F - 304 F
IAT	C, F	-40 C - 151 C, -40 F - 304 F
MAP	kPa / Volts	8-207 kPa, 0.00 - 4.98 volts
Baro	kPa / Volts	8-207 kPa, 0.00 - 4.98 volts
TP Sensor	Volts	0.00 - 4.98 volts
Throttle Angle	Percent	0 - 100%
Injector A Pulse Width	Milliseconds	0.0 - 500 ms
Injector B Pulse Width	Milliseconds	0.0 - 500 ms
Spark Advance	Degrees	-20 to 69.6484
Cam Retard	Degrees	0 to 90
Knock Retard	Degrees	0 to 89.6484
KS System Enabled	Yes/No	Yes/No
Knock Signal	Yes/No	Yes/No
IAC Position	Counts	0-255 counts
IAC Throttle Follower	Counts	0-255 counts
Closed Throttle	Yes/No	Yes/No
Vessel Speed	MPH	0-255
Battery Ignition Voltage	Volts	0.0 to 25.5
System Voltage Warning	Discrete	OK/Low Voltage
J1-20 Input	Discrete	On/Off
J2-20 Input	Discrete	On/Off
Emergency Stop Mode	Discrete	On/Off
Troll RPM Limit	Discrete	On/Off
Malfunction Indicator Lamp	Discrete	On/Off
Fuel Pump Relay	Discrete	On/Off
Cause Power Reduction	Discrete	On/Off
Power Reduction	Discrete	Yes/No
Overheat Detection	Discrete	Yes/No

Engine Scan Tool List (cont'd)

Scan Tool Parameter	Units	Parameter Range
Oil Pressure Input	Discrete	OK/Low Press
J1-9 Output	Discrete	On/Off
Oil Level Input	Discrete	OK/Low
Buzzer	Discrete	On/Off
J1-19 Input	Discrete	On/Off
J1-22 Output	Discrete	On/Off
J1-4 Input	Discrete	On/Off
J1-23 Output	Discrete	On/Off
Master/Slave	Discrete	Master/Slave
J1-7 RPM Output	Discrete	On/Off
Time From Start	Hour:Minutes:Seconds	00:00:00 - 18:12:15
Engine Hour Meter	Hours	0.0 - 1193046,47 hours
Fuel Consumption	Gallons per hour	0.0 - 255 gph
Fuel Pressure Volts	Volts	0.00 - 5.00 volts
Low Fuel Pressure Warning	Discrete	OK/Low Pressure
Fuel Temp	Volts	0-5 volts

Engine Scan Tool Data Definitions

The Engine Scan Tool Data Definitions contains a brief description of all engine related parameters available on the scan tool.

ECM Data Descriptions

CALIBRATION ID - Scan Tool Range 0-255 - This is an identification number given to each calibration by the OEM.

CALIBRATION CHECKSUM - Scan Tool Range 0-65535 - This number is automatically calculated by the ECM. This number may also be used as a calibration identifier.

ENGINE SPEED - Scan Tool Range 0-9999 RPM - Engine speed is computed by the ECM from the Ignition Control reference input. It should remain close to the desired idle under various engine loads with engine idling.

DESIRED IDLE - Scan Tool Range 0-3187 RPM - The idle speed that is commanded by the ECM. The ECM will compensate for various engine loads based on engine coolant temperature to keep the engine at the desired speed.

ECT - Scan Tool Range -40°C to 151°C, -40°F to 304°F - The Engine Coolant Temperature (ECT) sensor is mounted in the coolant stream and sends engine temperature information to the ECM. The ECM supplies 5 volts to the ECT sensor circuit. The sensor is a thermistor which changes internal resistance as temperature changes. When the sensor is cold (internal resistance high), the ECM monitors a high signal voltage and interprets it as a cold engine. As the sensor warms (internal resistance decreases), the voltage signal will decrease and the ECM will interpret the lower voltage as a warm engine.

IAT - Scan Tool Range -40°C to 151°C, -40°F to 304°F - The ECM converts the resistance of the intake air temperature sensor to degrees. Intake Air Temperature (IAT) is used by the ECM to adjust fuel delivery and spark timing according to incoming air density. (Big Block Multiport Fuel Injection Application Only).

MAP - Scan Tool Range 10-210 kPa/0.00-5.00 Volts - The Manifold Absolute Pressure (MAP) sensor measures the change in the intake manifold pressure from engine load and speed changes. As intake manifold pressure increases, intake vacuum decreases resulting in a higher MAP sensor voltage and kPa reading.

BARO - Scan Tool Range 10-105 kPa/0.00-5.00 Volts - The Barometric Pressure reading displayed is measured from the MAP sensor signal monitored at ignition "ON," engine "OFF" and WOT conditions. The Barometric Pressure is used to compensate for altitude differences.

TP SENSOR - Scan Tool Range 0.00-5.00 Volts - This

is the voltage being monitored by the ECM on the TP sensor signal circuit.

TP ANGLE - Scan Tool Range 0% - 100% - TP Angle is computed by the ECM from the TP Sensor voltage. TP Angle should display 0% at idle and 100% at wide open throttle.

FUEL CONSUMPTION - Scan Tool Range 0-100 gph - This is the gallons per hour of fuel that the engine is consuming.

INJ. PULSE WIDTH - Scan Tool Range 0-1000 msec. - Indicates the amount of time the ECM is commanding the injectors "ON" during each engine cycle. A larger injector pulse width will cause more fuel to be delivered. Inj. Pulse Width should increase with increased engine load.

SPARK ADVANCE - Scan Tool Range -90° to 90° - This is a display of the spark advance (IC) calculations which the ECM calculates and then provides all spark advance to the ignition system. The ECM computes the desired spark advance using data such as engine temperature, RPM, engine load, vessel speed, and operating mode. There is no adjustment for spark advance. The ECM also uses spark advance to help maintain idle speed. Under normal operating condition, with the engine warmed up and 0% throttle angle, it is normal to see timing vary continuously.

KNOCK RETARD - Scan Tool Range 0.0°-45.5° - Indicates the amount of spark the ECM is removing from IC spark advance in response to the signal from the knock sensor (KS).

KS ENABLED - Scan Tool Displays "YES" or "NO" - This is informing you whether or not the Knock System is enabled.

KNOCK SIGNAL - Scan Tool Displays "YES" or "NO" - Indicates whether or not a knock signal is being detected by the ECM. Should display "NO" at idle.

KNOCK SENSOR 1 - Scan Tool Displays "OK" or "Fault" - Indicates whether or not a fault is being detected on the knock sensor 1 circuit.

KNOCK SENSOR 2 - Scan Tool Displays "OK" or "Fault" - Indicates whether or not a fault is being detected on the knock sensor 2 circuit.

IAC POSITION - Scan Tool Range 0-255 - Displays the commanded position of the idle air control pintle in counts. A larger number of counts means that more air is being commanded through the idle air passage. Idle air control should respond fairly quickly to changes in engine load to maintain desired idle RPM.

IAC THROTTLE FOLLOWER - Scan Tool Range 0-255 - When the throttle is moved from the closed throttle position, some idle air control counts are added to prevent stalling when returned to the closed throttle position.

CLOSED THROTTLE - Scan Tool Displays "YES" or "NO" - Indicates whether the throttle is in the closed position.

VESSEL SPEED - Scan Tool Range 0-255 MPH - Indicates the speed of the vessel in MPH.

BATTERY / IGNITION VOLTAGE - Scan Tool Range 0.0 - 25.5 volts - This represents the system voltage

SYSTEM VOLTAGE WARNING - Scan Tool Displays "OK" or "LOW VOLTAGE" - Indicates if there may be a fault in the charging system.

J2-9 INPUT - Scan Tool Displays "ON" or "OFF" - This is a discrete input to the ECM that is determined and calibratable per OEM.

J2-20 INPUT - Scan Tool Displays "ON" or "OFF" - This is a discrete input to the ECM that is determined and calibratable per OEM.

EMERGENCY STOP MODE - Scan Tool Displays "YES" or "NO" - Indicates whether you are in emergency stop mode or not.

TROLL RPM LIMIT - Scan Tool Displays "ON" or "OFF" - This is a discrete input to the ECM which limits the RPM for such things as trolling. This RPM limit is calibratable by the OEM.

MIL - Scan Tool Displays "ON" or "OFF" - Indicates the ECM commanded state of the Malfunction Indicator Lamp.

FUEL PUMP RELAY - Scan Tool Displays "ON" or "OFF" - Indicates the ECM commanded state of the fuel pump relay driver circuit.

CAUSE POWER REDUCTION - Scan Tool Displays "YES" or "NO" - Indicates whether or not the ECM has recognized a fault which would put the engine into Power Reduction when the appropriate RPM is achieved.

POWER REDUCTION - Scan Tool Displays "YES" or "NO" - Indicates whether or not the ECM is functioning in Power Reduction mode. During this mode, the ECM only triggers one injector driver resulting in fuel to only half of the cylinders.

OVERHEAT DETECTED - Scan Tool Displays "YES" or "NO" - Indicates if the ECM has recognized an overheat condition with the engine.

OIL PRESSURE WARNING - Scan Tool Displays "OK" or "LOW PRESSURE" - Indicates if the ECM has recognized a fault in the oil pressure circuit.

CHECK GAUGES LAMP - Scan Tool Displays "ON" or "OFF" - Indicates the ECM commanded state of the Check Gauges lamp.

BUZZER - Scan Tool Displays "ON" or "OFF" - Indicates the ECM commanded state of the Buzzer.

GENERAL WARNING 1 - Scan Tool Displays "OK" or "Fault Detected" - This is a discrete input to the ECM that is determined and calibratable per OEM.

J1-21 OUTPUT - Scan Tool Displays "ON" or "OFF" - Indicates the ECM commanded state of this output circuit.

GENERAL WARNING 2 - Scan Tool Displays "OK" or "Fault Detected" - This is a discrete input to the ECM that is determined and calibratable per OEM.

J1-22 OUTPUT - Scan Tool Displays "ON" or "OFF" - ECM driven output that is determined and calibratable per OEM.

ECM MASTER / SLAVE - Scan Tool Displays "MASTER" or "SLAVE" - Indicates whether you are receiving data from a master or a slave engine.

J1-8 RPM OUTPUT - Scan Tool Displays "ON" or "OFF" - ECM driven output that is determined and calibratable per OEM.

TIME FROM START - Scan Tool Range 00:00:00-99:99:99 Hrs:Min:Sec - Indicates the amount of time the ignition key was in the "ON" or "RUN" position. Once the key has been cycled to the "OFF" position, this counter will reset to 00:00.

ENGINE HOUR METER - Scan Tool Range 00:00:00-99:99:99 Hrs:Min:Sec - Indicates the engine run time.

ECM Diagnostic Trouble Codes

The Malfunction Indicator Lamp (MIL) will be "ON" if the malfunction exists under the conditions listed below. If the malfunction clears, the lamp will go out and the Diagnostic Trouble Code (DTC) will be stored in the ECM. Any DTC's stored will be erased if no problem re-occurs within 50 engine starts. The amount of time after the malfunction occurs before the MIL illuminates is calibratable. (Instantly or up to one minute).

Many of the DTC tables include a functional check of the system that may pinpoint a problem. However, it is important to remember that the DTC tables are specifically designed for use only when a DTC is set. Therefore, a thorough understanding of the normal operation of the system being diagnosed is necessary, and use of the tables for this purpose is at the discretion of the technician.

NOTICE: Some DTC's are referred as "Latching Codes." A latching code will cause the MIL lamp to stay "ON" during an ignition cycle whether the malfunction is corrected or not. This also means you can not clear the DTC during the same ignition cycle.

Diagnostic Trouble Code (DTC) Table

DTC	Description
13	Oxygen Sensor Circuit 1 (inactive)
13	Oxygen Sensor Circuit 2 (inactive)
14	Engine Coolant Temperature (ECT) Sensor Circuit. Low Temperature Indicated
15	Engine Coolant Temperature (ECT) Sensor Circuit High Temperature Indicated
21	Throttle Position (TP) Sensor Circuit High Signal Voltage Indicated
22	Throttle Position (TP) Sensor Circuit Low Signal Voltage Indicated
23	Intake Air Temperature (IAT) Sensor Circuit Low Temperature Indicated
24	Not Used
25	Intake Air Temperature (IAT) Sensor Circuit High Temperature Indicated
31	Not Used
33	Manifold Absolute Pressure (MAP) Sensor Circuit High Signal Voltage Indicated
34	Manifold Absolute Pressure (MAP) Sensor Circuit Low Signal Voltage Indicated
41	Ignition Control (IC) H Fault
41	Ignition Control (IC) G Fault
41	Ignition Control (IC) F Fault
41	Ignition Control (IC) E Fault
41	Ignition Control (IC) D Fault
41	Ignition Control (IC) C Fault
41	Ignition Control (IC) B Fault
41	Ignition Control (IC) A Fault
44	Knock Sensor (KS) 1 Circuit
44	Knock Sensor (KS) 2 Circuit
51	Calibration Checksum Failure
54	Not Used

Diagnostic Trouble Code (DTC) Table (cont'd)

DTC	Description
55	Not Used
61	Not Used
62	Not Used
63	Not Used
64	Not Used
81	Crankshaft Position (CKP) Sensor Circuit Fault
81	Camshaft Position (CMP) Sensor Circuit Fault
81	Injector Driver A Circuit High, Low, Open
81	Injector Driver B Circuit High, Low, Open
81	Recirc J1-32 Fault
81	5 Volt Reference Circuit Out of Range
81	DEPSPWR Circuit out of Range
81	CAN Bus Fault

Logged Warnings

These warnings will be displayed following the Diagnostic Trouble Codes. They can be cleared the same as the trouble codes. Unlike trouble codes, these warnings can not be flashed out through the MIL using the DTC tool.

Clearing Diagnostic Trouble Codes - Non Scan

1. Install Diagnostic Trouble Code (DTC) tool.
2. Ignition "ON," engine "OFF."
3. Switch DTC tool to "service mode" or "ON."
4. Move the throttle from 0% (idle) to 100% (WOT) and back to 0%.
5. Switch DTC tool to "normal mode" or "OFF" (If this step is not performed, the engine may not start and run).
6. Turn ignition "OFF" for at least 20 seconds.
7. Ignition "ON," engine "OFF."
8. Switch DTC tool to "service mode" or "ON" and verify DTC 12 only. Remove MDTC tool.
9. If original DTC's are still present, check "Notice" below and repeat the DTC clearing procedure.
10. If new DTC's are displayed, perform the "On-Board Diagnostic" (OBD) system check.

Clearing Diagnostic Trouble Codes - Scan

1. Install scan tool.
2. Start engine.
3. Select "Clear DTC's" function.
4. Clear DTC's.
5. Turn ignition "OFF" for at least 20 seconds.
6. Turn ignition "ON" and read DTC's. If DTC's are still present, check "Notice" below and repeat procedure following from step 2.

NOTICE: When clearing DTC's with or without the use of a scan tool, the ignition must be cycled to the "OFF" position or the DTC's will not clear.

General Information

All *Delco* Distributor Ignition (DI) systems include these essential components: battery, distributor, ignition coil, ignition switch, spark plugs, and primary and secondary wiring. The Distributor Ignition (DI) system is connected to the Engine Control Module (ECM). The ECM monitors various engine sensors, computes the desired spark timing and signals the Ignition Control module in the distributor to change timing. The distributor does not contain centrifugal advance weights, springs, or vacuum advance units.

1 The distributor used on marine Electronic Fuel Injection equipped engines is designed for the marine environment. The distributor base plate is equipped with two special vents to prevent fuel vapors from igniting.

The ignition coil connects to the distributor through a high tension secondary wire and two low voltage primary wires. Due to the high voltage produced by the coil, a special material is used for the distributor cap and rotor. It is a thermoplastic, injection molded, glass reinforced polyester. This material provides the required dielectric and insulation property, and also prevents carbon tracking. The posts in the distributor cap are made up of durable metals to prevent corrosion.

1 The distributor uses an internal magnetic pickup assembly that consists of a permanent magnet, pole piece with internal teeth, and a pickup coil. The pickup coil is sealed to keep out moisture and prevent electromechanical interference. When the rotating teeth of the timer core line up with the teeth of the pole piece, voltage is induced in the pickup coil. This voltage signals the Ignition Control module to trigger the primary ignition circuit. Current flow in the primary circuit is interrupted and high voltage of up to 35,000 volts is induced in the ignition coil secondary winding. This high voltage is directed through the secondary ignition circuit to fire the spark plugs.

The number of teeth on the stationary pole piece, and on the timer core's rotating shaft, reflects the number of cylinders in the engine (i.e. 8 teeth for eight cylinders). Although there are minor differences between applications, all DI systems operate the same.

There is no scheduled maintenance or periodic lubrication required. Engine oil lubricates the lower bushing, and the upper bushing is pre-lubricated and sealed.

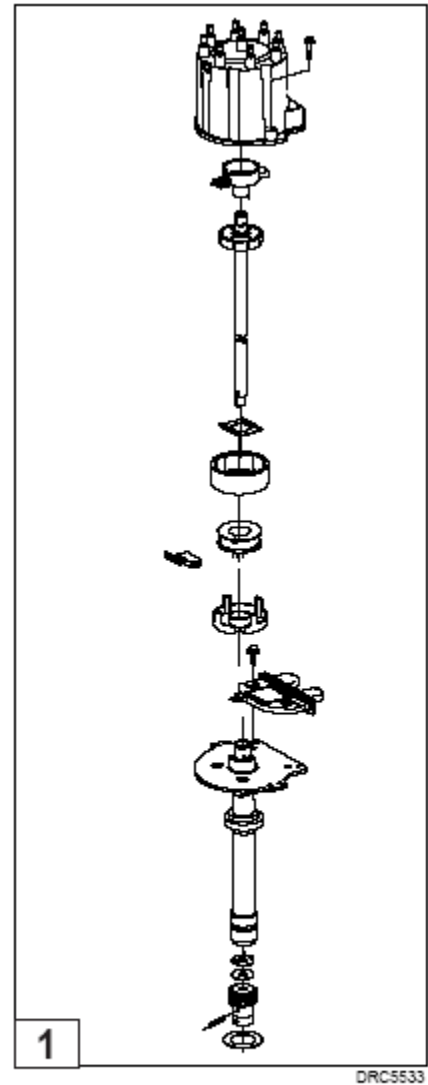

DISASSEMBLY

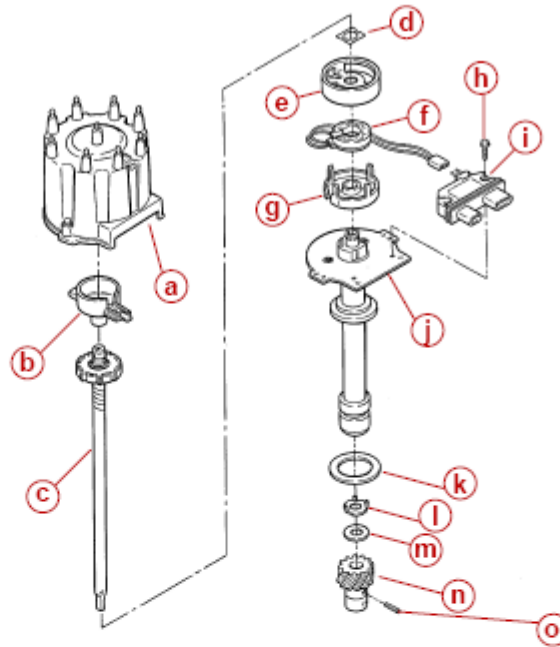

72411

- a - Cap
- b - Rotor
- c - Shaft Assembly
- d - Retainer
- e - Shield
- f - Pickup Coil
- g - Pole Piece
- h - Screw
- i - Module
- j - Housing
- k - Gasket
- l - Tang Washer
- m - Washer
- n - Gear
- o - Pin

NOTE: Whenever disassembling distributor, the retainer (d) must be replaced. DO NOT attempt to use old retainer.

Ignition Coil

The design and construction of the ignition coil affects its output. The DI system ignition coil was designed to produce greater spark voltage, longer spark, and operate at higher RPM. The DI system coil has the secondary windings wrapped around the primary windings. The primary windings are wrapped around an iron core. The coil is not oil filled. The windings are covered in an epoxy compound for protection against moisture and arc-over.

There is an iron laminated square frame around the coil windings. This increases the magnetic flux path and stores energy to produce higher secondary spark voltage. The coil's mounting bracket is attached to the frame.

2 The coil generates a high secondary voltage (up to 35,000 volts) when the primary circuit is broken. It is attached to the distributor by a high tension wire connected to the post **Ⓘ** mounted on top of the coil. The coil has a pair of 2-wire connectors. They're used for battery voltage input **Ⓒ**, primary voltage sent to the distributor Ignition Control module **Ⓙ**, trigger signal from the Ignition Control module **Ⓛ**, and for a tach output signal **Ⓜ**.

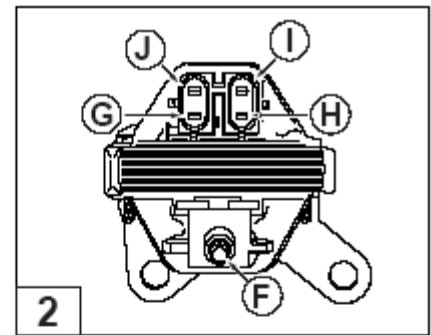

2

DR3302

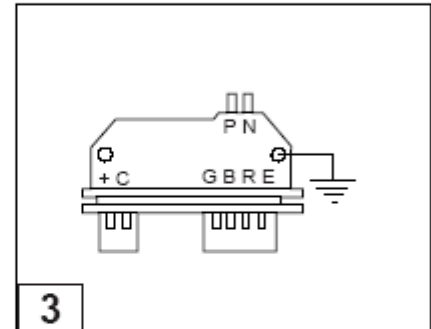

3

DR5532

Ignition Control (IC) Module

3 The Ignition Control (IC) module is located in the distributor. It is mounted by two screws that are used for a ground. The IC module is a solid state unit with transistorized relays and switches for controlling circuits. The IC module has several functions:

- It changes the analog signal **Ⓛ** of the pickup coil to a square digital signal.
- It sends the digital signal as a reference signal (REF HI) **Ⓜ** to the ECM for ignition control.
- It provides a ground reference (REF LO) **Ⓝ**.
- It provides a means for the ECM to control spark advance (BYPASS **Ⓞ** and IGNITION CONTROL **Ⓟ**) called Ignition Control Mode.
- It provides a limited means of controlling spark advance without ECM input, called Module Mode.
- It provides the trigger signal **Ⓠ** for the ignition coil.

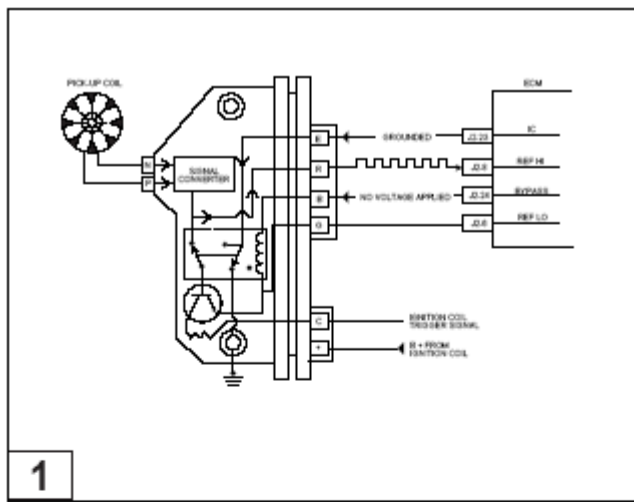

IC Operation - Module Mode (Cranking)

1 The following describes IC operation during cranking and when the engine starts running. To help understand how IC circuits operate, a relay with a double set of contact points is shown inside the IC module. Actually solid state circuitry is used, but showing a relay makes it easier to visualize how the IC functions.

1 During cranking, the relay is in a de-energized position. This allows a set of contact points to connect the pickup coil to the base of the transistor. When the pickup coil applies a positive voltage to the transistor, it turns "ON". When voltage is removed, the transistor turns "OFF". When the transistor turns "ON", current flows through the primary windings of the ignition coil. When it turns "OFF", the primary current stops and a spark is developed at the spark plug. A small amount of advance is built into the IC module, in case the engine remains in Module Mode.

1 With the relay de-energized, a set of contacts (shown "closed") would ground the IC line signal. No voltage is applied by the ECM to the BYPASS line.

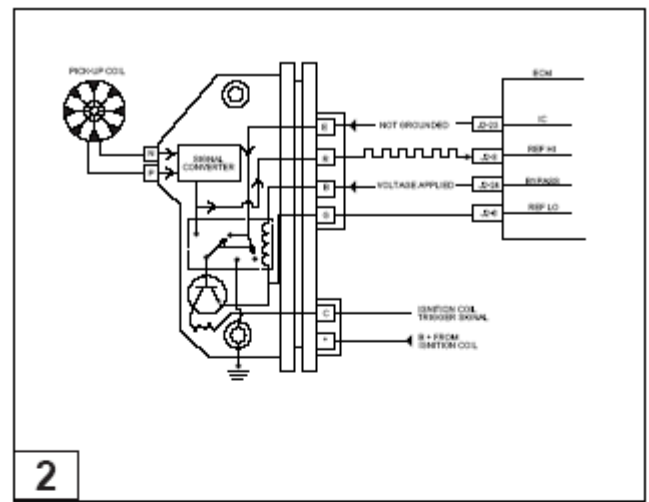

IC Operation - Ignition Control Mode (Running)

2 The ECM constantly monitors engine RPM through the REF HI line. When engine RPM reaches a predetermined value (for this example 400 RPM), the ECM considers the engine running and applies five volts on the BYPASS line to the IC module. This energizes the relay and causes contact set for the pickup coil as well as contact set for the IC line to open. This connects the IC line to the base of the power transistor, and bypasses IC module timing control.

The DI system is now controlled by the timing (IC) signal from the ECM, and the time at which the spark occurs can be determined by a variable time circuit in the ECM.

Results Of Incorrect Operation_____

An open or ground in the BYPASS circuit or connector will cause the engine to run in Module Mode. This will cause reduced performance and poor fuel economy.

Open IC Line

While the engine is cranking, the ECM expects to see the IC signal pulled to virtually zero because it's grounded inside the IC module. If the IC line is open, it cannot be grounded by the module. The ECM IC signal will be able to rise and fall, or do what is called "tog-gling". The ECM recognizes "tog-gling" as an abnormal condition, and will not apply bypass voltage to the IC module when the engine reaches run RPM.

Since bypass voltage is not applied to the relay, it re-mains open. The engine continues to run on pick-up coil triggering, and stays in Module Mode. If this condition were to occur while the engine was running, the engine would stop, but it would restart and run in Module Mode with reduced power.

Grounded IC Line

During cranking, IC voltage would be at virtually zero so the ECM would not recognize a problem. When engine RPM reaches the value for the run condition, the ECM would apply bypass voltage to the IC module. Bypass voltage at the module switches the IC power transistor to the IC line. Because the IC line is grounded, it would have no voltage applied and could not operate the power transistor in order to enter Ignition Control Mode.

If the IC line should become grounded while the engine was running, the engine would stop and be difficult to restart.

Grounded Or Open BYPASS Line

While the engine is cranking, the IC line would be grounded and the ECM would not notice anything ab-normal. When run RPM is reached, the ECM would ap-ply voltage to the BYPASS line but because of the ground or open, it would not be able to energize the relay. There-fore, the relay would stay de-energized and the IC line would remain grounded.

When the ECM sees the IC line not "tog-gling" (i.e. not rising and falling), it will not enter Ignition Control Mode. Since the relay is de-energized, the engine would con-tinue to run in Module Mode.

If this condition were to occur while the engine was run-ning, it would simply operate in Module Mode.

Open Or Grounded REF Hi Line

This line provides the ECM with engine speed (RPM) information. If this line were open or grounded, the ECM would not know that the engine is cranking or running, and would not make any attempt to control spark.

Open Or Grounded REF LO Line

This wire is grounded in the IC module and provides a reference ground from the IC module to the ECM. The ECM compares reference ground with reference high voltage. If this circuit is open, or grounded at any other location than through the IC module, it may cause poor performance.

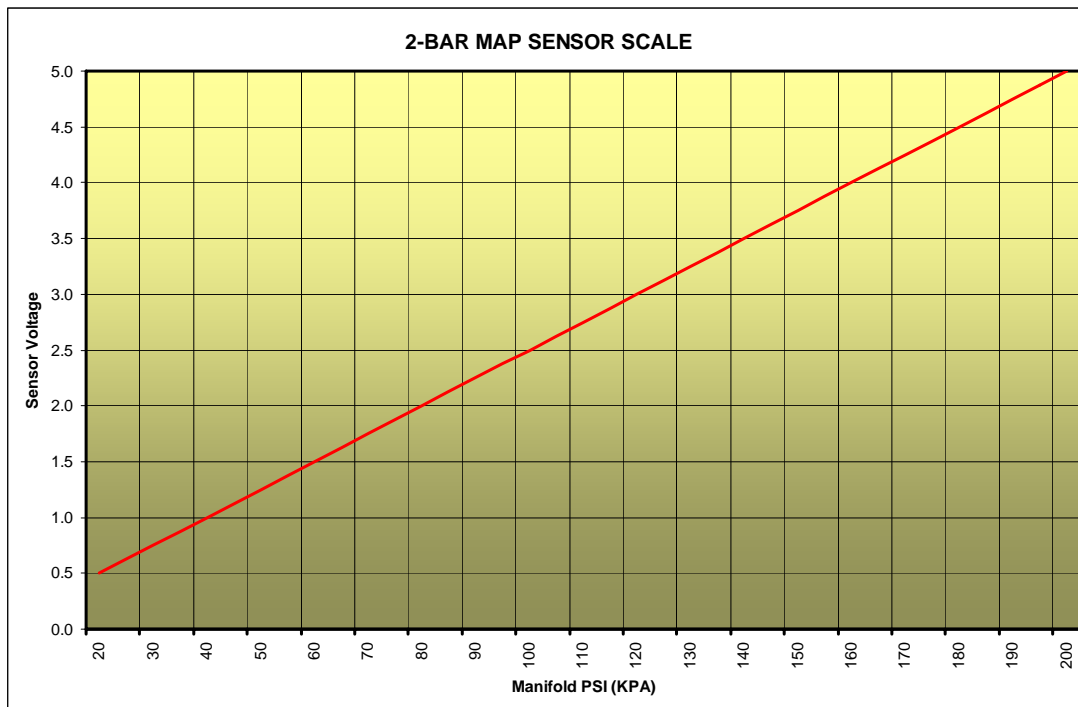



LIMITED WARRANTY

All merchandise manufactured by Whipple Industries is fully warranted against defects in workmanship and materials to the original purchaser of the Whipple Supercharger System. The limited warranty must be signed, dated and returned to Whipple Industries within 14 days of the purchase date accompanied by a copy of the original sales invoice.

If an item is suspected of being defective, return it to Whipple Industries for inspection after obtaining the proper Return Authorization Number. If an item is determined to be defective, we will repair or replace it at our discretion within a period of one year from the shipping date on your invoice.

Whipple Industries Inc. limited warranty specifically does not apply to products which have been (a) modified or altered in any way, (b) subjected to adverse conditions such as misuse, neglect, accident, improper installation or adjustment, dirt, or other contaminants, water, corrosion or faulty repair; or (c) used in other than those specifically recommended by Whipple Industries Inc. All products designed for off-road use are considered racing parts and carry no warranty, either expressed or implied, as we have no control over how they are used.

On warranty items, repair/replacements will be limited to parts manufactured by Whipple Industries and will not include claims for labor or inconvenience. All other merchandise distributed by Whipple Industries is warranted in accordance with the respective manufacturer's own terms of warranty. This warranty is expressly made in lieu of any and all other warranties expressed or implied, including the warranties of merchantability and fitness.

Whipple Industries will not be responsible for any other expenses incurred by the customer under the terms of this warranty, nor shall it be responsible for any damages either consequential, special, contingent, expenses or injury arising directly or indirectly from the use of these products.

Whipple Industries reserves the right to determine whether the terms of the warranty, set out above, have been properly complied with. In the event that the terms are not complied with, Whipple Industries shall be under no obligation to honor this warranty. By signing this form, you understand and agree to the terms above.

NAME (Print) _____ ADDRESS _____

SIGNATURE _____ CITY _____ STATE _____ ZIP _____

DATE _____ PHONE _____

SC SERIAL # _____ EMAIL _____
(Found on compressor bearing plate) (Optional)

VIN OR VESSEL # _____

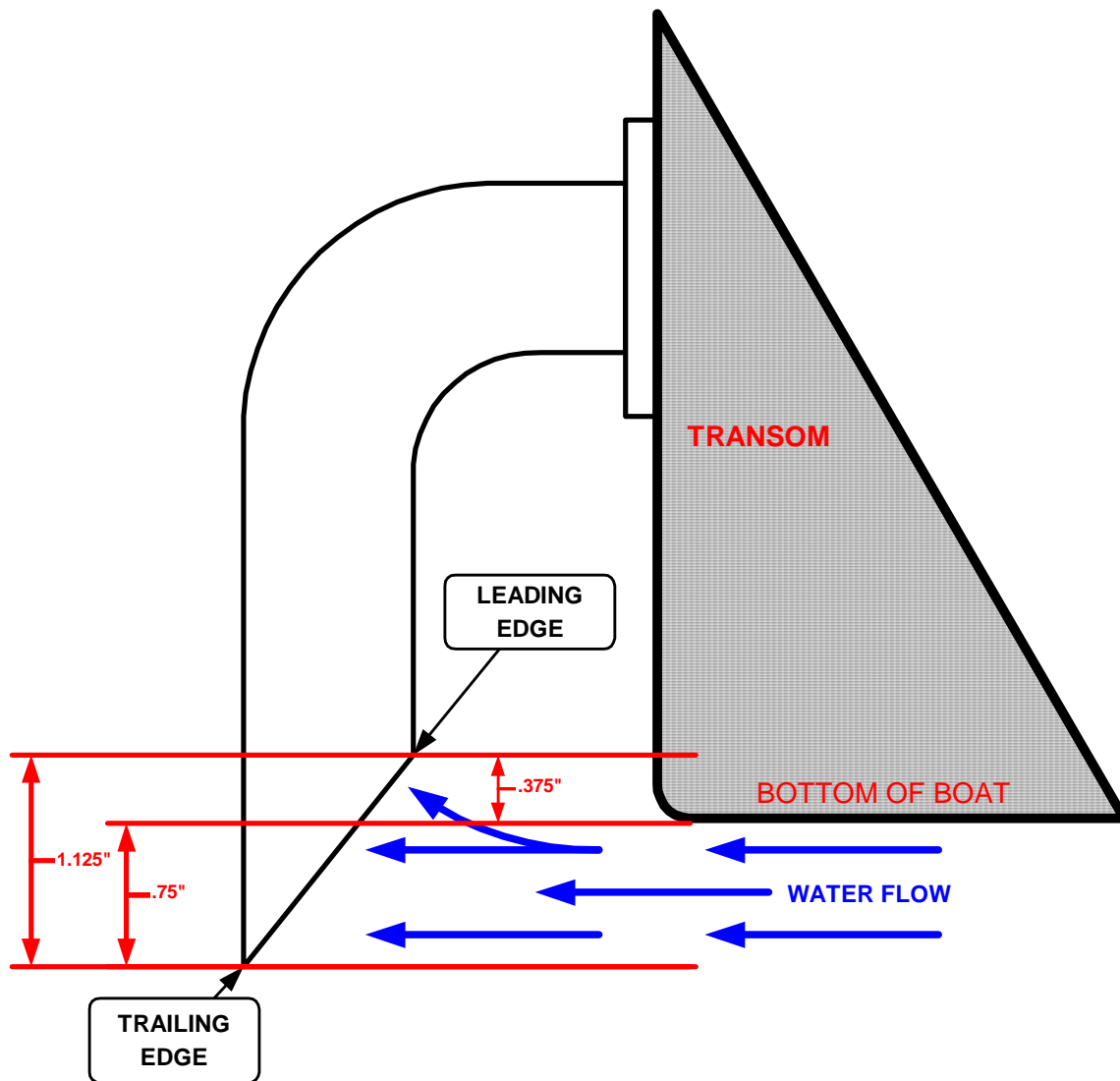

- ⦿ For transom intercooler water pickups, install as shown in diagram.
- ⦿ For engine water pickups, you want your trailing edge to only hang between .325-.625".
- ⦿ When running separate water pickups, the fuel cooler must be in the factory water loop and not routed in the intercooler loop. The fuel cooler needs water at idle and slow boat speeds, the intercooler will not feed it if it's not in the sea pump system.

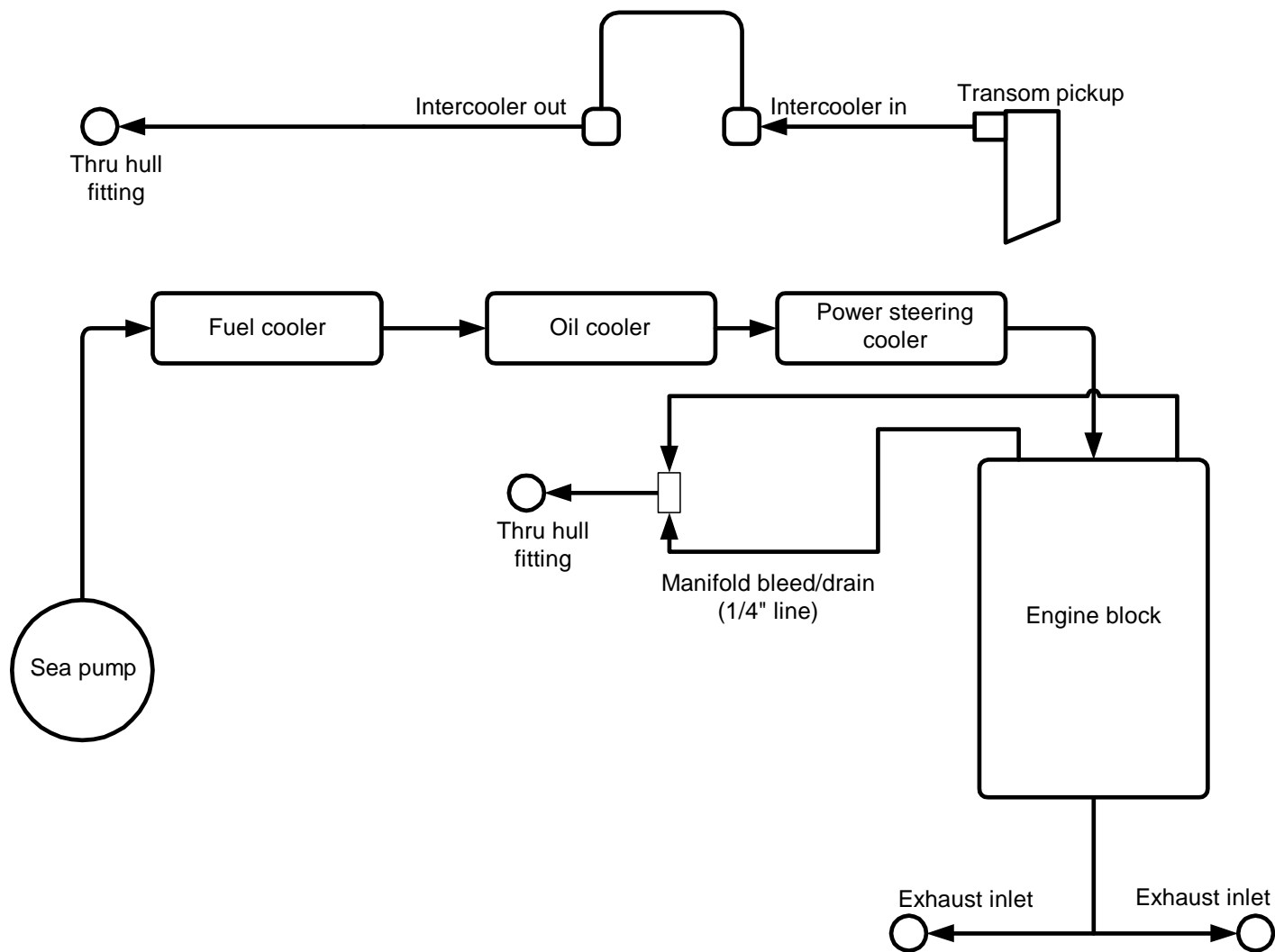

Water system routing for use without intercooler tee