

HARDIN MARINE

PART NUMBER: 137-9151 (REVISED 07/13/12)

DESCRIPTION:
MAYFAIR INSIDE HYD. POWER STEERING KIT FOR 1 BRAVO, 2 BRAVO,
#3 SSM or #5SSM w/ DUAL CYLINDERS

HARDIN MARINE TECH LINE:
386-445-2500
www.hardin-marine.com

**NOTE: IT IS THE INSTALLERS
RESPONSIBILITY TO HAVE ALL HOSE
ASSEMBLIES, ASSEMBLED &
PRESSURE TESTED TO 2000 PSI
PRIOR TO INSTALLATION.**

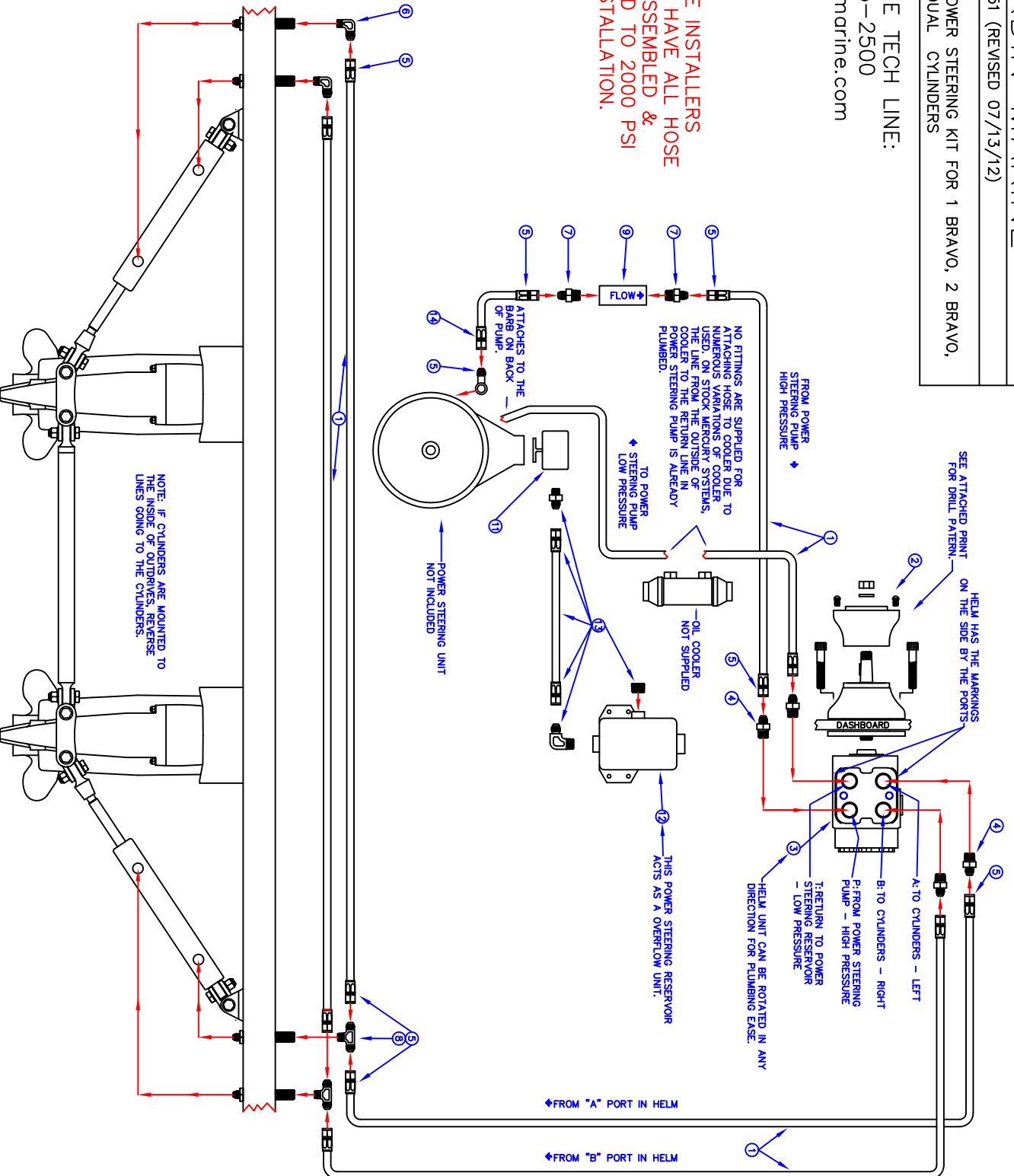

ITEM	QTY.	PART NO.	DESCRIPTION
1	80'	137-9301	HOSE, -6 HYDRAULIC
2	1	137-9120	STEERING COLUMN w/4" WHEEL ADAPTER
3	1	137-9146	HELM, DUAL CYLINDER POWER STEERING
4	4	137-9360	FITTING, HELM O-RING ADAPTER
5	13	137-9303	HOSE END, -6 JIC - STRAIGHT - BRASS
6	2	137-9363	FITTING, 1/4 NPT x -6 JIC MALE - 90 DEGREE - BRASS
7	2	137-9366	FITTING, 3/8 NPT x -6 JIC MALE - STRAIGHT - BRASS

ITEM	QTY.	PART NO.	DESCRIPTION
8	2	137-9358	FITTING, 1/4 NPT x -6 JIC MALE - TEE - BRASS
9	1	135-1030	FILTER, POWER STEERING - HIGH PRESSURE
10	1	136-1013	FITTING, HIGH PRESSURE BANJO - POWER STEERING PUMP
11	1	135-1010	CAP, RETURN - POWER STEERING PUMP
12	1	137-9001	RESERVOIR, REMOTE MOUNT - POWER STEERING
13	1	137-9158	REMOTE RESERVOIR HOSE & FITTING KIT

HARDIN MARINE 11 Industry Dr. Palm Coast, FL 32137
386-445-2500 / FAX 386-445-1122

PART NO.
137-9120

THESE DIMENSIONS ARE THE REQUIRED DEPTH NEEDED BEHIND THE DASHBOARD FOR PROPER INSTALLATION WITH HARDIN HYDRAULIC HELMS.
137-9145 SINGLE RAM HELM: 5-1/2"
137-9146 DUAL RAM HELM: 5-13/16"
137-9147 QUAD RAM HELM: 6-5/16"

TITLE:
4" STEERING COLUMN

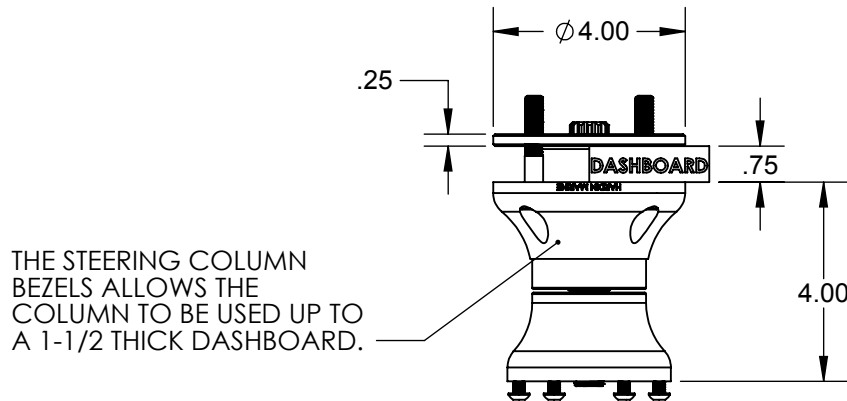
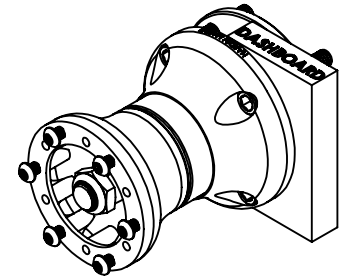

THE STEERING COLUMN POSITIONS THE STEERING WHEEL MOUNTING FACE 4" AWAY FROM DASHBOARD, BASED ON 3/4 DASHBOARD THICKNESS. FOR ADDITIONAL SIZES, HARDIN ALSO SELLS 137-9121 6" COLUMN AND 137-9122 8" COLUMN.

STEERING WHEEL HUB IS THREADED FOR BOTH DINO & MOMO 6 BOLT HOLE PATTERNS. COLUMN COMES WITH (6) 1/4-20 x 5/8 BUTTON HEAD CAP SCREWS FOR MOUNTING THE STEERING. THIS COLUMN CAN BE USED WITH OPTIONAL 137-9130 MOMO HORN BUTTON OR 137-9131 DINO HORN BUTTON.

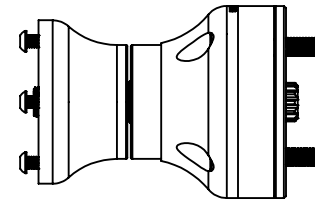
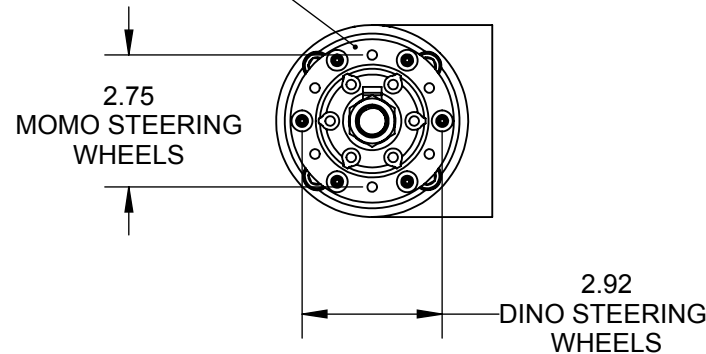

KIT INCLUDES (4) 3/8-16x2" SOCKET CAP SCREWS TO MOUNT COLUMN THROUGH THE DASH TO THE HYDRAULIC HELM. BECAUSE DASHBOARD SIZES VARY, PLEASE INSURE THE BOLTS DO NOT BOTTOM OUT INTO THE HYDRAULIC HELM. HELM NEEDS TO BE SECURELY FASTENED AGAINST COLUMN.

HARDIN MARINE

PART NUMBER: 137-9120

DESCRIPTION:

MAYFAIR STEERING COLUMN w/ 4" WHEEL ADAPTER

HARDIN MARINE TECH LINE:

EAST COAST 386-445-2500

WEST COAST 707-585-9006

www.hardin-marine.com

ITEM	QTY.	PART NO.	DESCRIPTION
1	6	90025C062BHS	SCREW - BHCS - SS - 1/4x5/8
2	1	137-9104	ADAPTER, 4" STEERING WHEEL - MAYFAIR
3	4	90037C200SHS	SCREW - SHCS - SS - 3/8-16x2
4	1	137-9103	BEZEL, STEERING COLUMN - MAYFAIR
5	1	137-9128	MAYFAIR STEERING COLUMN BASE UNIT

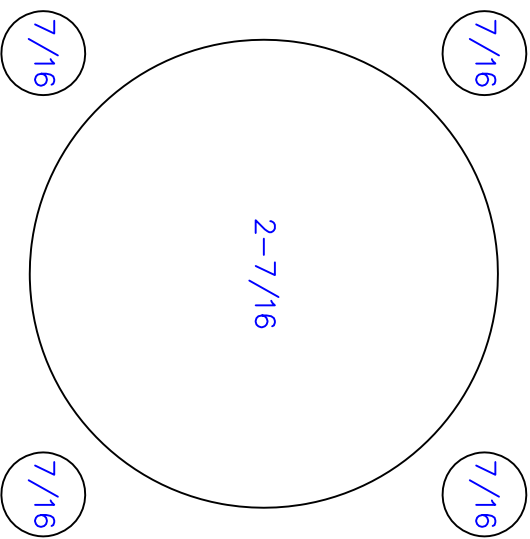

DRILL TEMPLATE:
CUT OUT AND TAPE TO DASHBOARD. THIS WILL INSTALL THE HELM LIKE PICTURE BELOW OR AT ANY 90 DEGREES.

